

## INTRODUCTION

---

To the owner or user: The service manual you are reading is intended to provide you, and the maintenance or service technician, with the information needed to install, start up, clean, maintain, and service this ice system.

The product is a remote condenser modular ice system. It features: front service for the freezer, gear motor, control box, water reservoir, and bin control; an electronic circuit for monitoring ice and water level; and R-404A as the refrigerant.

## TABLE OF CONTENTS

FOR THE INSTALLER . . . . .	Page 2
FOR THE INSTALLER . . . . .	Page 3
REMOTE CONDENSER SPECIFICATIONS . . . . .	Page 4
FOR THE INSTALLER . . . . .	Page 5
FOR THE INSTALLER: Remote Condenser . . . . .	Page 6
FOR THE INSTALLER: Precharged Lines . . . . .	Page 7
FOR THE INSTALLER: Location . . . . .	Page 8
FOR THE PLUMBER . . . . .	Page 9
FOR THE ELECTRICIAN . . . . .	Page 10
FOR THE INSTALLER: Completed Installation . . . . .	Page 11
FOR THE INSTALLER: Final Check List . . . . .	Page 12
START UP . . . . .	Page 13
COMPONENT DESCRIPTION . . . . .	Page 14
COMPONENT DESCRIPTION: Control Box . . . . .	Page 15
ELECTRICAL SEQUENCE . . . . .	Page 16
OPERATION: Water . . . . .	Page 17
OPERATION: Refrigeration . . . . .	Page 18
MAINTENANCE AND CLEANING . . . . .	Page 20
SERVICE DIAGNOSIS: Condition - No Ice Being Produced . . . . .	Page 23
SERVICE DIAGNOSIS: Condition - Low Ice Production . . . . .	Page 26
REMOVAL AND REPLACEMENT: Water Reservoir & Bin Controls . . . . .	Page 27
REMOVAL AND REPLACEMENT: Bearing And Breaker . . . . .	Page 28
REMOVAL AND REPLACEMENT: Auger . . . . .	Page 29
REMOVAL AND REPLACEMENT: Water Seal . . . . .	Page 30
REMOVAL AND REPLACEMENT: Evaporator . . . . .	Page 31
REMOVAL AND REPLACEMENT: Gear motor Assembly . . . . .	Page 32
REFRIGERATION SYSTEM SERVICE . . . . .	Page 33
CIRCUIT BOARD TESTING . . . . .	Page 34

***Parts Lists and Wiring Diagrams are located in the center of this manual, printed on yellow paper.***

The manual was printed on recycled paper. Keep it for future reference.

Note the Warning symbol where it appears. It marks a possible hazard.



# NME1850R & FME2400R

## FOR THE INSTALLER

These machines are designed to fit the following Scotsman storage bins:

- B90 and extensions, with bin top KBT18.
- BH800 no bin top needed.
- BH900 using bin top KBT14.

When installing a new system, check to be sure that you have everything you need before beginning:

- Correct Bin
- Correct Ice Machine
- Correct Bin Top
- All kits, legs, and information required for the specific job.

There are two separate ice making and refrigeration systems in this model. The liquid and discharge lines from each system must go to separate circuits in one remote condenser (RCE502).

TOP VIEW

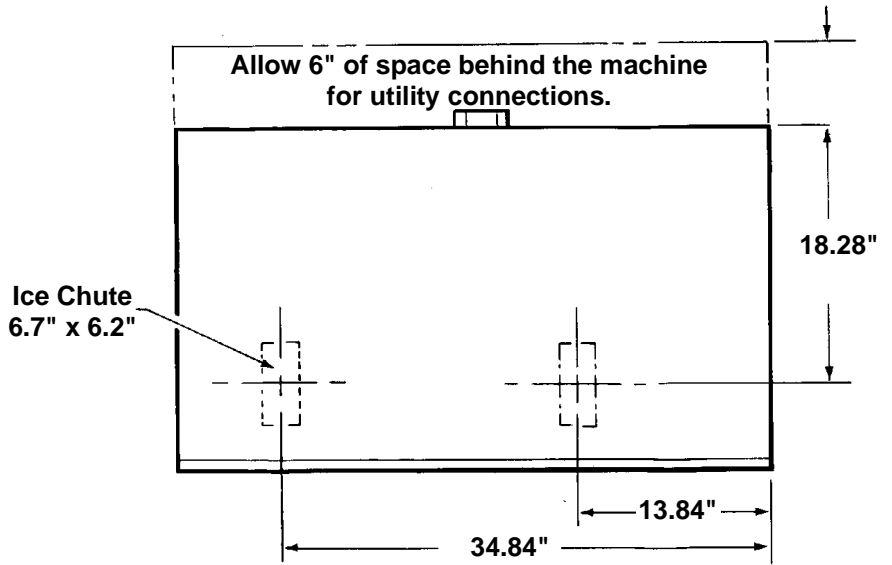

BACK VIEW

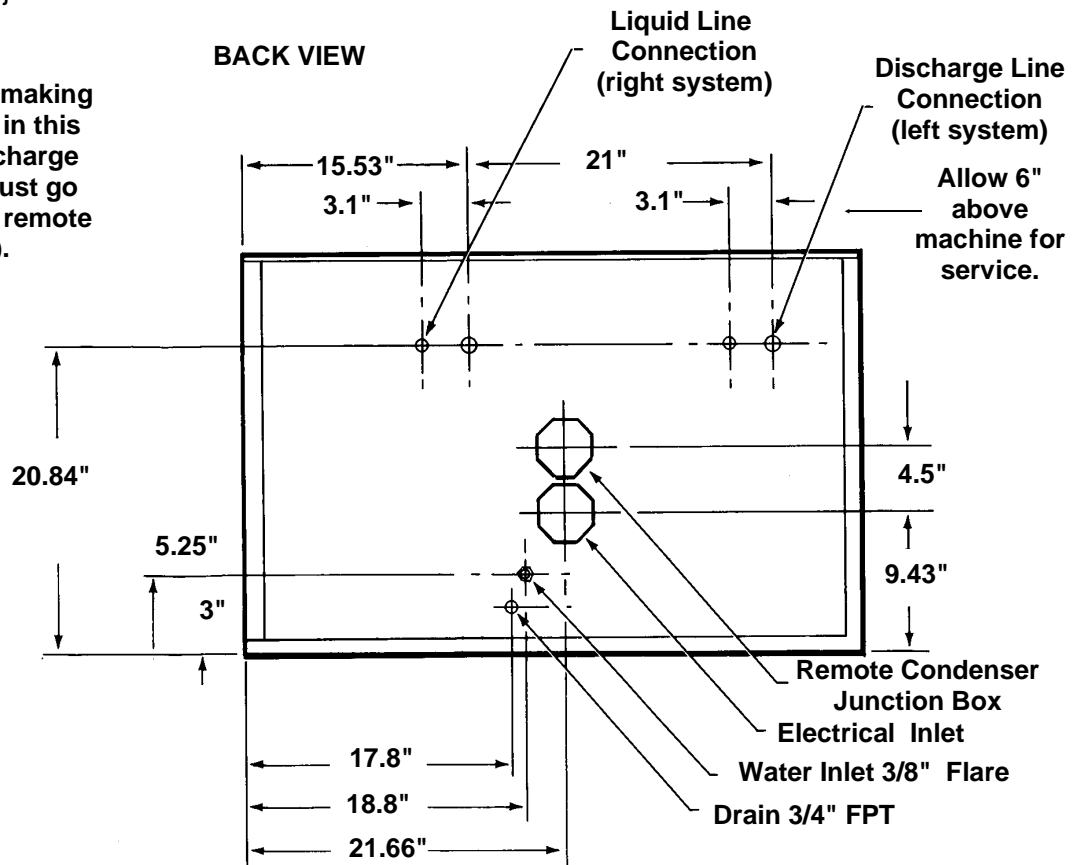

### SPECIFICATIONS: ICE MAKER

Model Number	Dimensions (w/o bin) H X W X D	Basic Electrical	Ice Type	Cond. Type
FME2400RE-32A	27" x 42" x 24"	208-230/60/1	FLAKE	R/Air
FME2400RE-3A	same	208-230/60/3	same	R/Air
*NME1850RE-32A	same	208-230/60/1	Nugget	R/Air
NME1850RE-3A	same	208-230/60/3	same	R/Air

The Standard Finish is Enamel - Sandalwood. There is an optional stainless steel panel kit, SPKFM42 available to convert the unit to Stainless Steel. It is field installed.

## FOR THE INSTALLER

### Installation Limitations:

This ice system is designed to be installed indoors, in a controlled environment:

	Min	Max
Air Temperature (Not including the remote condenser)	50 <sup>0</sup> F	100 <sup>0</sup> F
Water Temperature	40 <sup>0</sup> F	100 <sup>0</sup> F
Water Pressure	20 PSIG	80 PSIG
Voltage (Compared to the nameplate)	-5%	+10%

Operating the machine outside of the limitations is misuse and can void the warranty.

### Water Limitations:

An ice machine is a food manufacturing plant; it takes a raw material, water, and turns it into a food product, ice. The purity of the water is very important in obtaining pure ice and in maximizing product life. This is not intended as a complete resource for water related questions, but it does offer these general recommendations:

1. Check with a water treatment specialist for a water test, and recommendations regarding filters and treatment.
2. In most cases, the water used to make ice should be filtered or treated, depending upon the water. *There is no one type of water filter that will be effective in all situations.* That is why a water test is important.

Scotsman Ice Systems are designed and manufactured with the highest regard for safety and performance. They meet or exceed the standards of UL, NSF, and CUL.

Scotsman assumes no liability or responsibility of any kind for products manufactured by Scotsman that have been altered in any way, including the use of any part and/or other components not specifically approved by Scotsman.

Scotsman reserves the right to make design changes and/or improvements at any time. Specifications and design are subject to change without notice.

### Typical Storage Bin - B90

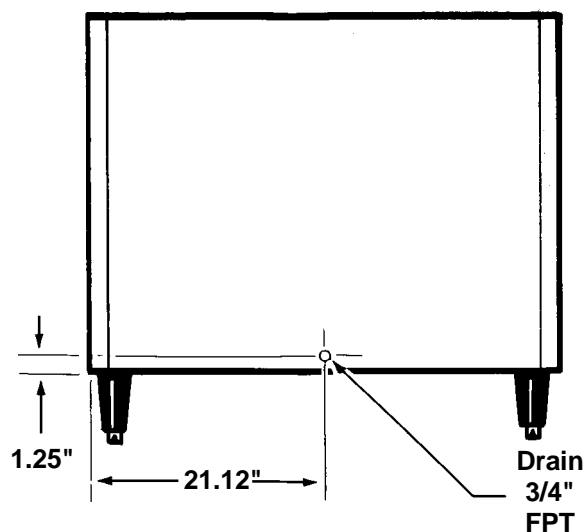

# NME1850R & FME2400R

## REMOTE CONDENSER SPECIFICATIONS

Model	Use with	Basic Electrical
RCE502-32	1 FME2400R or NME1850R	208-230/60/1
ERC302-32	SAME	SAME

### ERC DIMENSIONS

Model	A	B	F	G
ERC302	43 3/8"	10 3/4"	21 3/4"	16 5/8"

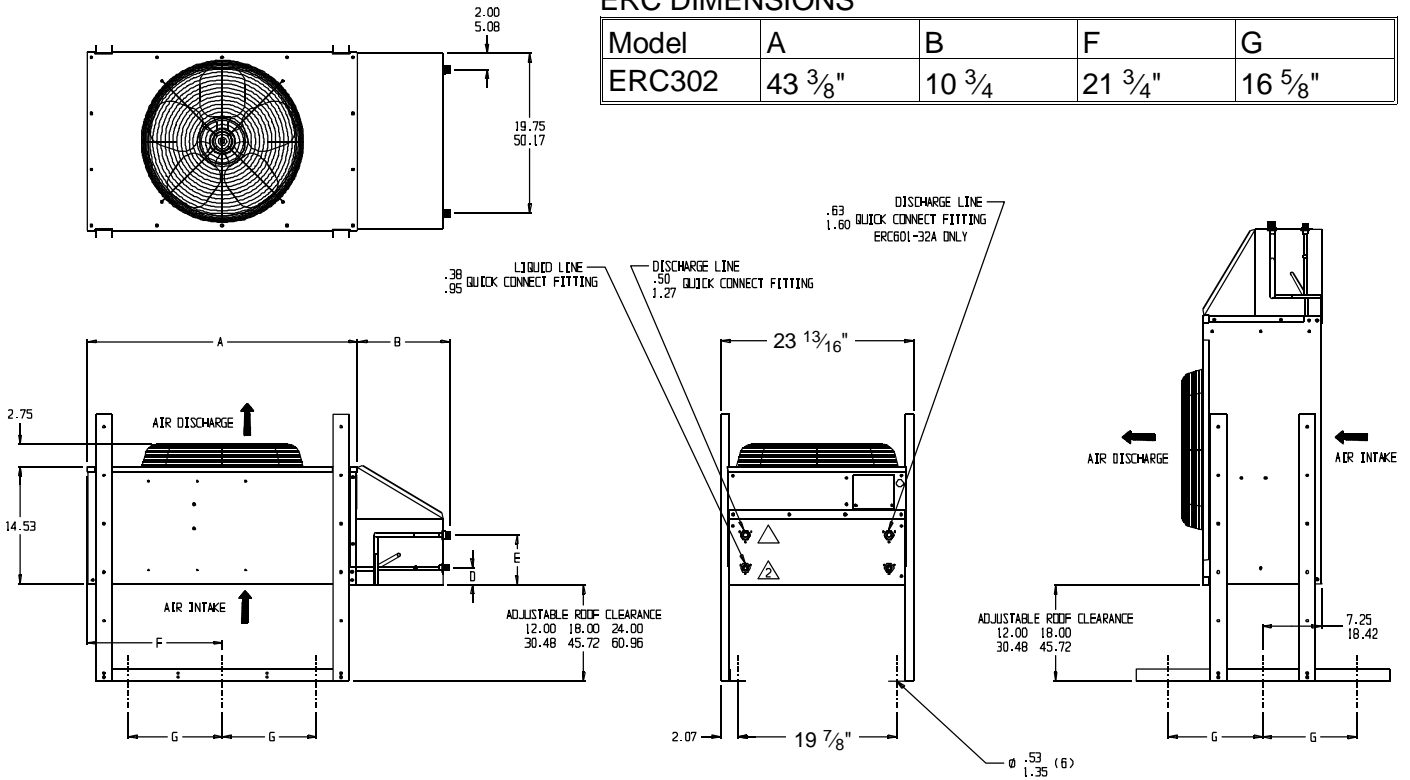

### Other Required Items:

RTE25 Precharged line set, 25', R-404A - 2 required.

Or: RTE40. Precharged line set, 40', R-404A - 2 required.

**MODEL NUMBER**  
**SERIAL NUMBER**  
**A.C. SUPPLY VOLTAGE**  
**MINIMUM CIRCUIT AMPACITY**  
**MAXIMUM FUSE SIZE \***  
**HEATER WATTS**  
**REFRIGERANT**      **CHARGE**      **OZ.**  
**MOTORS**      **VOLTS**      **RLA/FLA W/HP.**      **LRA**  
**COMPRESSOR**  
**FAN**  
**DRIVE**  
**OTHER**  
**DESIGN PRESSURE**      **LOW**      **HIGH**  
 \* OR HACR TYPE CIRCUIT BREAKER

**SCOTSMAN**

FAIRFAX OPERATION  
FAIRFAX, SOUTH CAROLINA U.S.A.

**ICE MAKER NAMEPLATE  
LOCATED ON BACK PANEL**

**SERIAL PLATE LOCATED  
BEHIND FRONT PANEL**

**REMOTE CONDENSERS AND BINS ALSO  
HAVE MODEL AND SERIAL NUMBERS**

*Typical Storage Bin with Extension and Bin Top*

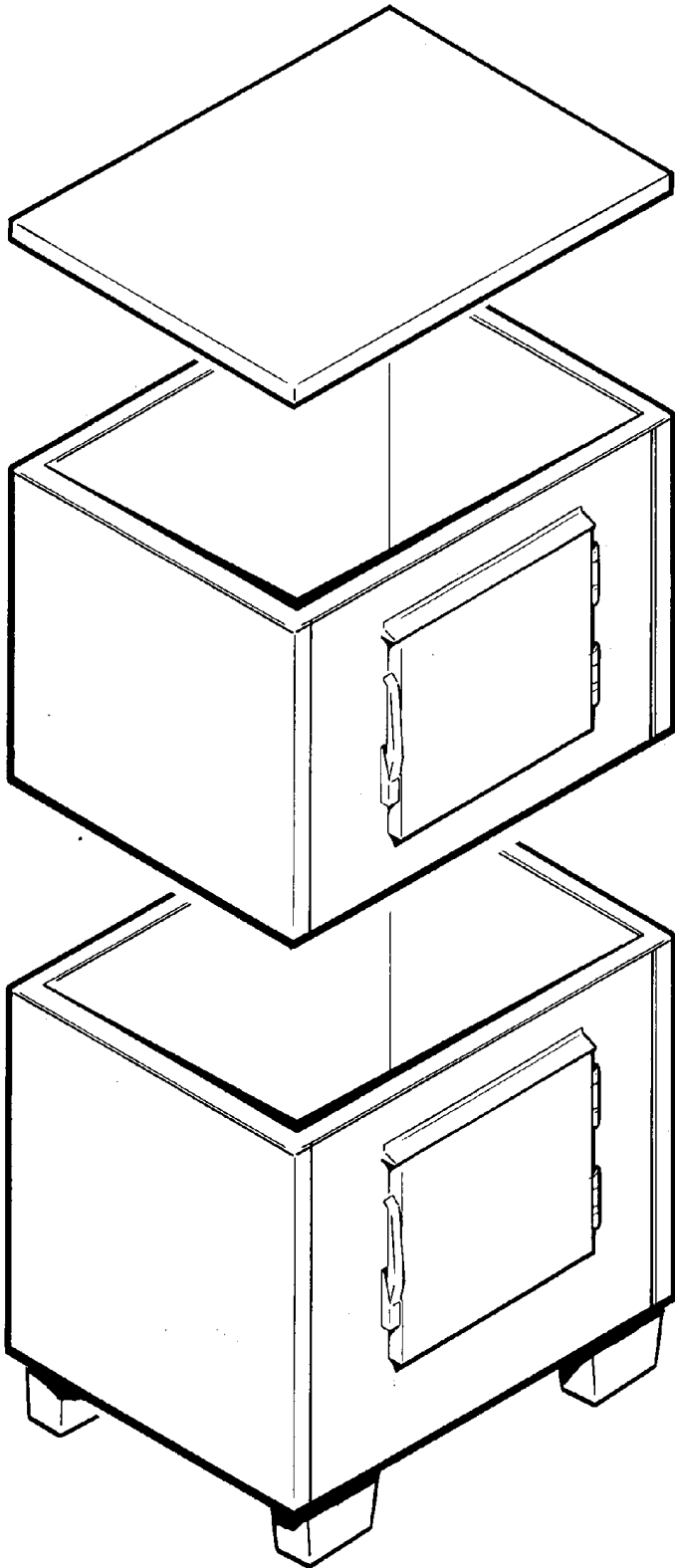

### Location

After uncrating and inspection, the unit is ready for installation. It is important that the machine be installed in a location where it has enough space around it to be accessible for service, usually a minimum of 6 inches. Try to avoid hot, dirty and crowded locations. Be sure that the location for the machine is within the limitations described on page 3.

### Storage Bin

Tip the storage bin on its back, using parts of the carton to protect the exterior finish. Install the legs into the threaded holes in the bottom of the bin. Turn the leg levelers all the way in preparation for leveling later. Return the bin to the upright position, remove paper covering the bin gasket.

Install the bin top according to the directions with the bin top.

**Note:** Do not push bin into position, but lift it there. Pushing a bin, especially one with ice in it, can cause damage to the legs and the leg mounts.

### Ice Maker

The machine is heavy, so the use of a mechanical lift is recommended for lifting the machine high enough to install on top of the bin. After the unit is placed on the bin, line it up so it is even with the back side. Secure the machine to the bin with the hardware provided with the machine.

Remove the front panel and remove any shipping blocks.

**Note:** *Be sure to allow a 6" minimum space above the top of the machine for service.*

# NME1850R & FME2400R

## FOR THE INSTALLER: Remote Condenser

### Location

Limited to a 40 foot or a 25 foot length of precharged refrigerant tubing connecting the ice maker to the remote condenser. The condenser must be above or level with the ice maker.

Select the best available location, protecting the condenser from extremes of dirt, dust, and sun. Meet all applicable building codes. Usually the services of a licensed electrician are required.

### Roof Attachment

1. Install and attach the remote condenser to the roof of the building, using the methods and practices of construction that conform to the local building codes, including having a roofing contractor secure the condenser to the roof.

2. Have an electrician connect the remote condenser fan motor to the ice maker, using the junction box at the back of the ice maker.

### PRECHARGED LINE ROUTING

#### CAUTION

Do not connect precharged tubing until all routing and forming of the tubing is complete. See the coupling instructions for connecting instructions.

1. Each set of precharged refrigerant lines (either 25 foot or 40 foot) consists of a 3/8 inch diameter liquid line and a 1/2 inch diameter discharge line. Both ends of each line have quick connect couplings, one end has a schrader valve connection, that end goes to the condenser.

Note: The openings in the building ceiling or wall, listed in the next step, are the minimum sizes recommended for passing the refrigerant lines through.

2. Have the roofing contractor cut a minimum hole for the refrigerant lines of 1 3/4 inch. Check local codes, a separate hole may be required for the electrical power to the condenser.

#### CAUTION

DO NOT KINK OR CRIMP REFRIGERANT TUBING WHEN INSTALLING IT.

3. Route the refrigerant lines through the roof opening.

Follow straight line routing whenever possible.

Any excess tubing MUST be retained within the building.

4. Spiral the excess length of pre charged tubing inside the building. Use a horizontal spiral (as illustrated) to avoid any traps in the lines.

5. Have the roofing contractor seal the holes in the roof per local codes.

**Note: Tight spiral shown is not required, bend tubing to a practical radius.**

**Refrigerant charge is in the ice maker. Only a holding charge is in the "pre-charged" lines.**

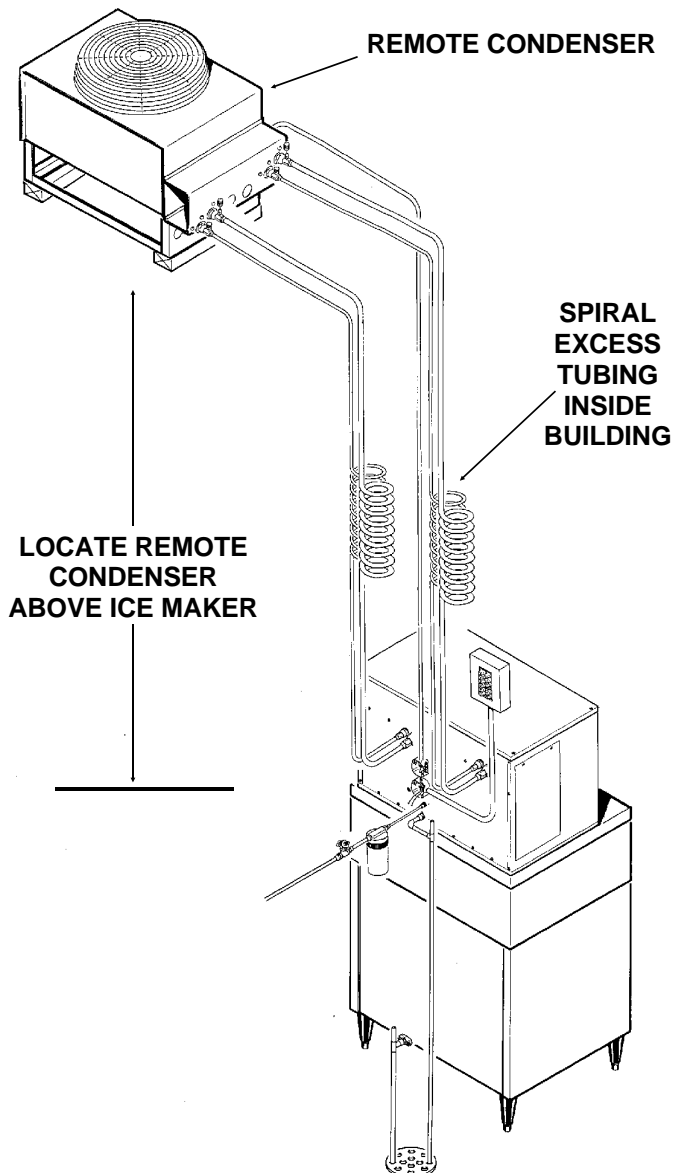

# NME1850R & FME2400R

## FOR THE INSTALLER: Precharged Lines

### COUPLING INSTRUCTIONS

#### CAUTION

The couplings on the sets of precharged lines are self sealing when installed properly. Carefully follow the instructions:

1. Remove the protector caps and plugs. Wipe the seats and threaded surfaces with a clean cloth to be certain that no foreign matter remains on them.
2. Lubricate the inside of the couplings, especially the O-Rings with refrigerant oil.

- Connect the 3/8 inch liquid line (schrader valve end) to the remote condenser fitting marked "liquid line".
- Connect the other end of the liquid line to the ice maker fitting marked "liquid line."
- Connect the 1/2 inch discharge line (schrader valve end) to the remote condenser fitting marked "discharge line".
- Connect the other end of the liquid line to the ice maker fitting marked "discharge line".

3. Begin tightening the couplings together by hand, then using two wrenches (it is important that ONLY the nut on the precharged lines be turned, the other parts of the couplings must NOT be allowed to turn or the process will tear out the diaphragms and they will be loose in the refrigeration system) tighten the coupling until it bottoms out or a definite increase in resistance is felt.

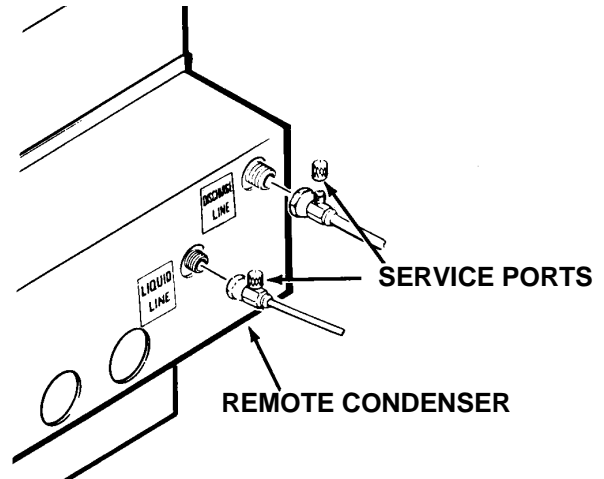

4. Using a marker or pen, mark a line lengthwise from the coupling union nut to the bulkhead. Then tighten the coupling and additional 1/4 turn. As the nut turns, the line will show when 1/4 turn is made.
5. After all connections are made, and after the king valve has been opened, check the couplings for leaks.

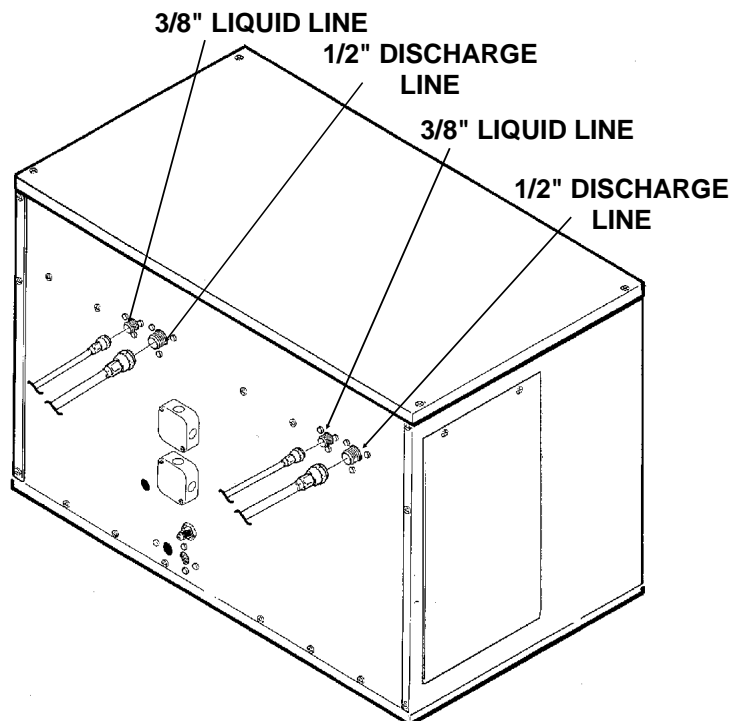
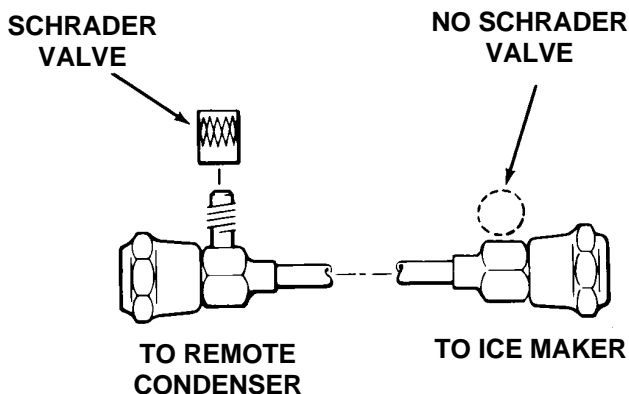

# NME1850R & FME2400R

## FOR THE INSTALLER: Location

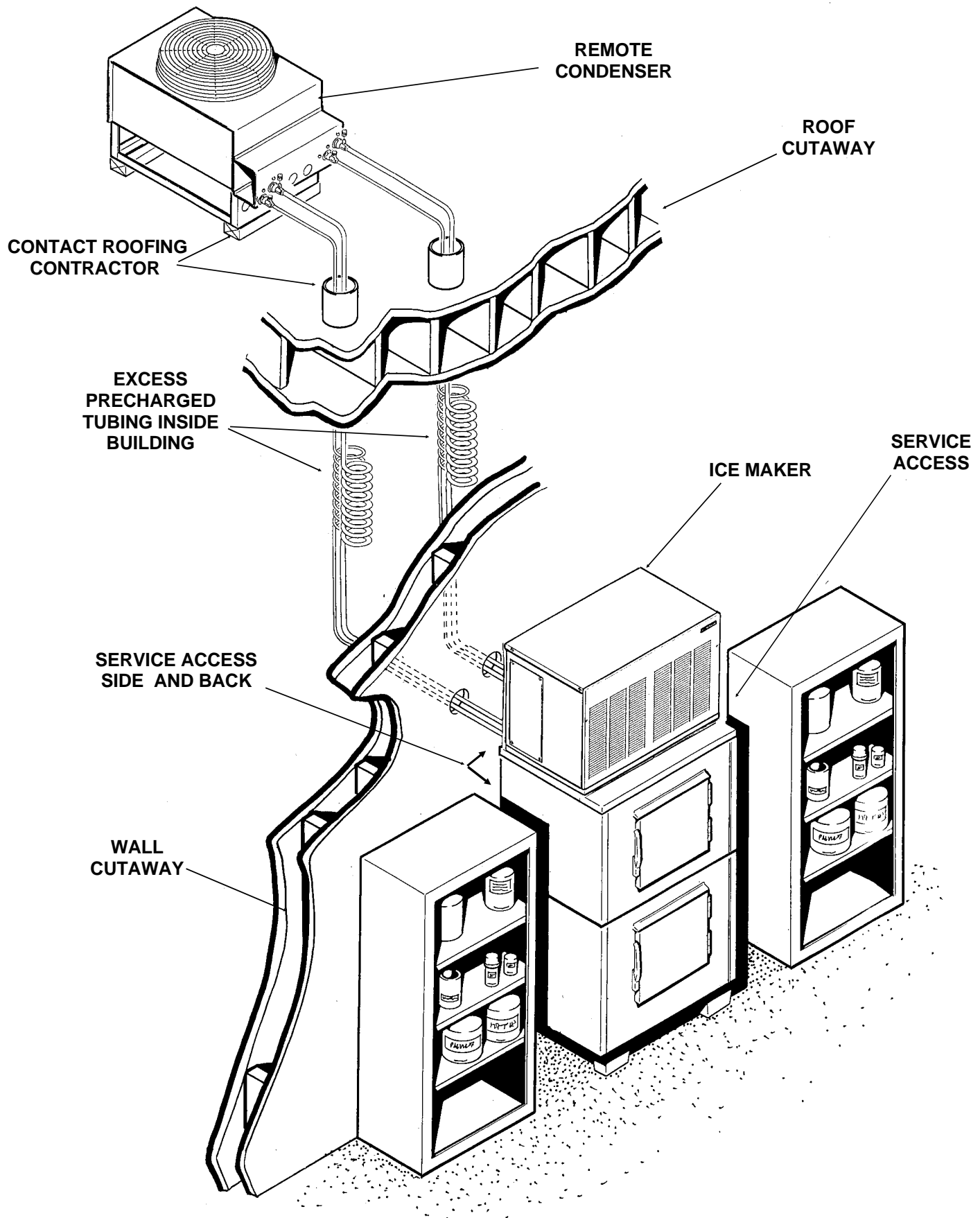



# NME1850R & FME2400R

FOR THE PLUMBER

CONFORM TO ALL APPLICABLE CODES

## Water Inlet

The recommended water supply is cold water. Use 3/8" O.D. copper tubing, connect to the 3/8" male flare at the back of the cabinet. Install a hand valve near the machine to control the water supply.

## Drains

There is one 3/4" FPT drain at the back of the cabinet, the drain line is of the gravity type, and 1/4 inch per foot fall is an acceptable pitch for the drain tubing. There should be a vent at the highest point of the drain line, and the ideal drain receptacle would be a trapped and vented floor drain. Use only 3/4" rigid tubing.

**Storage Bin:** A separate gravity type drain needs to be run. Insulation of this drain line is recommended.

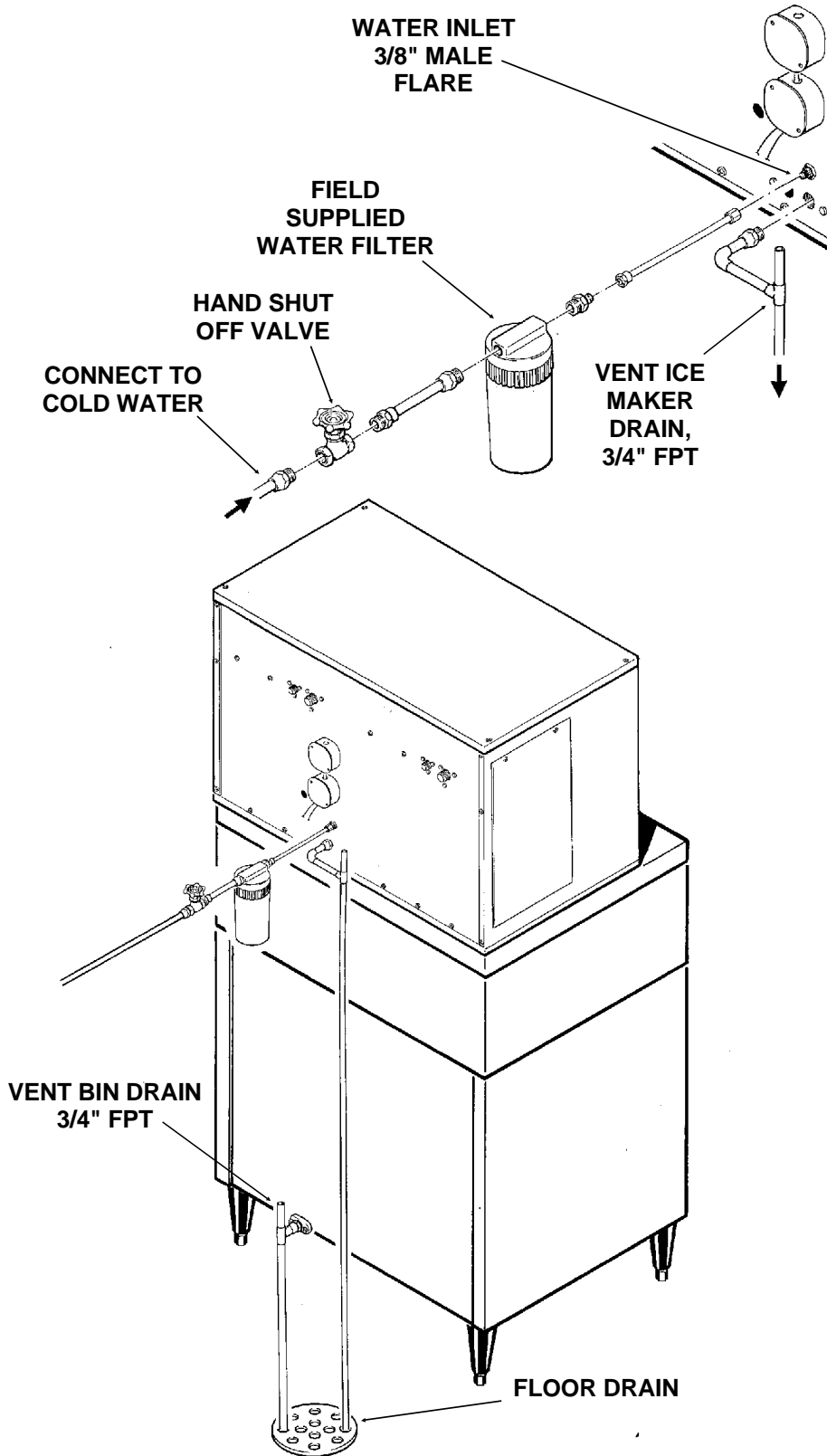

# NME1850R & FME2400R FOR THE ELECTRICIAN

## CONFORM TO ALL APPLICABLE CODES

The electrical power to the unit is supplied through the junction box at the rear of the machine.

Check the nameplate (located on the back panel) for the voltage requirements, and for the minimum circuit ampacity. The machine requires a solid chassis to earth ground wire.

The ice maker should be connected to its own electrical circuit so it would be individually fused. Voltage variation must remain within design limitations, even under starting conditions.

Electrically the remote condenser fan motor is connected to the ice maker at the contactor

terminals for the compressor and the fan motor operates whenever the compressor operates.

Electrical connections are made at the junction box at the back of the ice maker and at the junction box on the remote condenser.

The remote condenser must be wired to the ice maker in accordance with local and national electrical codes with a minimum of 18 Awg. wire with an ground bonding wire connected to the ground screws provided in both the condenser and machine field wiring boxes. All outdoor wiring must be in rain proof conduit.

**All external wiring must conform to national, state, and local electrical codes. The use of a licensed electrician is required to perform the electrical installation.**

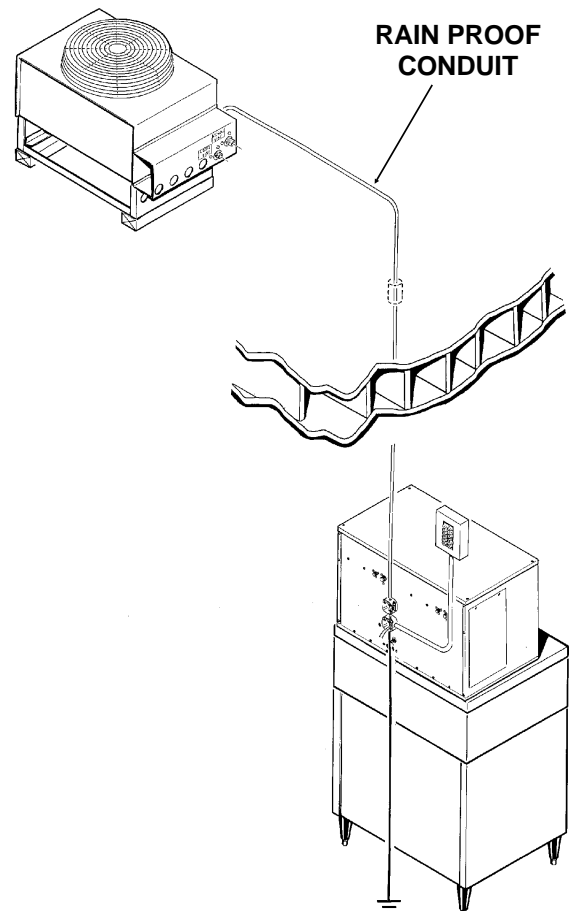
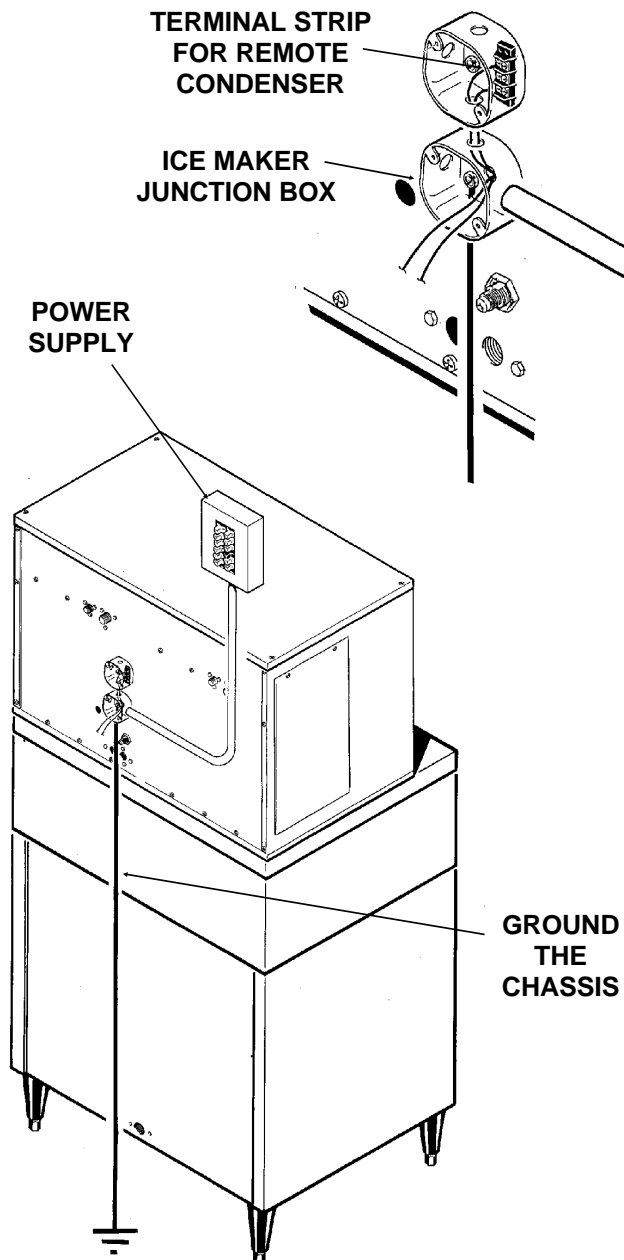

# NME1850R & FME2400R

## FOR THE INSTALLER: Completed Installation

A typical installation should generally appear as illustrated below. The remote condenser must be located above the ice maker and the precharged lines installed per the instructions on page 6.

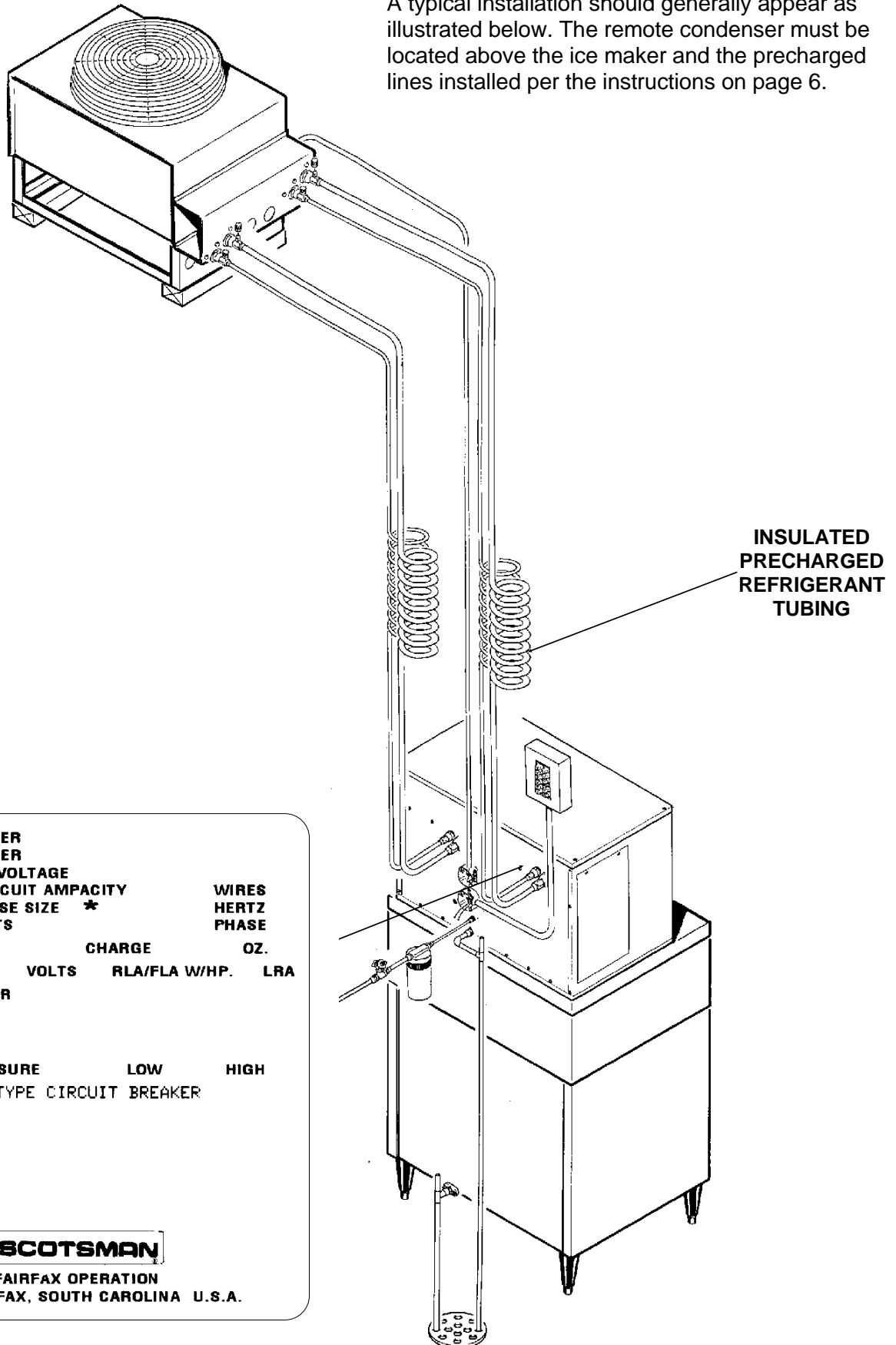

MODEL NUMBER				
SERIAL NUMBER				
A.C. SUPPLY VOLTAGE				
MINIMUM CIRCUIT AMPACITY			WIRES	
MAXIMUM FUSE SIZE *			HERTZ	
HEATER WATTS			PHASE	
REFRIGERANT		CHARGE	OZ.	
MOTORS	VOLTS	RLA/FLA W/HP.	LRA	
COMPRESSOR				
FAN				
DRIVE				
OTHER				
DESIGN PRESSURE		LOW	HIGH	
* OR HACR TYPE CIRCUIT BREAKER				

**SCOTSMAN**  
 FAIRFAX OPERATION  
 FAIRFAX, SOUTH CAROLINA U.S.A.

# NME1850R & FME2400R

## FOR THE INSTALLER: Final Check List

1. Is the ice system installed indoors in a location where the air and water temperatures are controlled, and where they do not exceed the design limitations?
2. Is there an electrical service disconnect within sight of the installed machine? Has the voltage been checked, and compared to nameplate requirements?
3. Have all the plumbing connections been made and checked for leaks?
4. Has the machine and bin been leveled?
5. Is there a minimum of 6" clearance at the rear, left, right and above the machine for proper service access?
6. Is the water pressure a minimum of 20 psig?
7. Has the machine been secured to the bin?
8. Is there a water shut off valve installed near the machine?
9. Is the remote condenser installed per local building codes, and in a place where it has adequate ventilation and minimal solar heat gain?
10. Has all shipping material and literature (inside the front panel) been removed from the units?
11. Have the remote condenser and precharged lines been properly installed?
12. Has the electrical connection between the ice maker and the condenser been made?
13. Verify that the master switches are in the OFF position.
14. Switch on the electrical power.

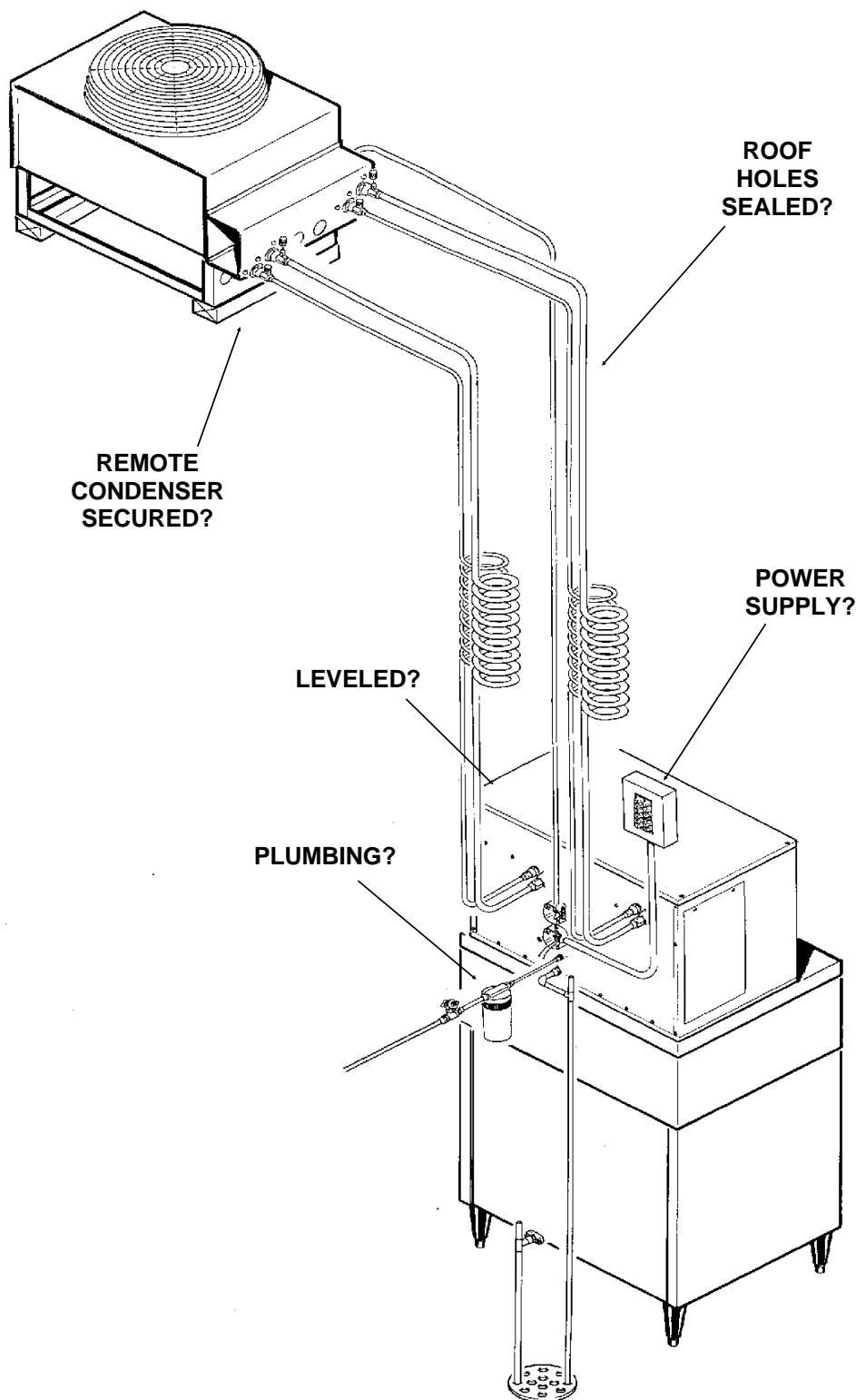

15. Refer to Pre-Start instructions, the next page.

## START UP

---

### Pre-Start Inspection

1. Remove the front, left, and right side service panels.
2. Check that any styrofoam shipping blocks have been removed.
3. Inspect the interior of the machine for loose screws or wires. Check that no refrigerant lines are rubbing each other. Check that the fan blade turns freely (remote condenser).
4. Check that the refrigerant lines are properly installed.
5. Check that the electrical power has been on for at least 4 hours and that the compressor domes are warm.
6. Check that the unit is installed correctly according to the final check list on page 12.

### Start Up

1. Go through the pre-start inspection.
2. Open the hand valve, observe that water enters the water reservoirs, fills the tubes from the reservoirs to the evaporators, and then shuts off. Check for leaks.
3. Open each King (receiver service) valve.
4. Switch each master switch on.  
The electrical start up sequence is now on automatic.
  - A. There should be a short (15 second) delay before the gear motor starts.
  - B. After the gear motor starts, the liquid line valve will open, the low pressure control will close and the compressor will start.
5. The remote condenser fan turns, and the condenser begins to discharge warm air.
6. The unit should soon be making ice, if desired the low side pressure of each system can be checked, it should be 32 psig + or - 2 psig. The discharge pressure will depend upon air and water temperatures, but should be between 205 psig and 280 psig.
7. **THERE ARE NO ADJUSTMENTS TO MAKE**, so replace the panels.
8. Clean and/or sanitize the storage bin interior, wipe off the exterior with a clean, damp cloth.
- 9 Give the owner/user the service manual, instruct him/her in the operation of the unit, and make sure they know who to call for service.
10. Fill out the manufacturers registration card, and mail it to Scotsman.
11. Fill out the field quality audit form, and mail it to the Scotsman factory.

# NME1850R & FME2400R

## COMPONENT DESCRIPTION

**Control Box:** Contains the electrical controls that operate the machine.

**High Pressure Cut Out:** A manual reset switch sensing the high side refrigeration pressure. It is set to shut the machine off at 450 psig.

**Evaporator:** A vertical stainless steel tube, refrigerated, and water filled. In it, there is a stainless steel auger.

**Reservoir:** Float operated, it maintains the water level in the evaporator at a constant level, it also contains the water level sensor.

**Water Level Sensor:** Senses if there is water in the reservoir to make ice out of. Will shut the machine off if there is none.

**Ice Discharge Chute:** Directs the ice produced by the evaporator into the storage bin.

**Ice Level Sensor:** An electronic "eye", it senses the presence of ice in the bottom of the ice discharge chute. Operates to turn the ice machine on and off automatically as the level of ice in the bin changes.

**Gear Motor:** An oil filled, speed reduction gearbox, driving the auger.

**Cleaning Drain Tube:** When uncapped and lowered, drains the evaporator.

**Compressor:** The refrigerant vapor pump.

**Expansion valve:** The refrigerant metering device.

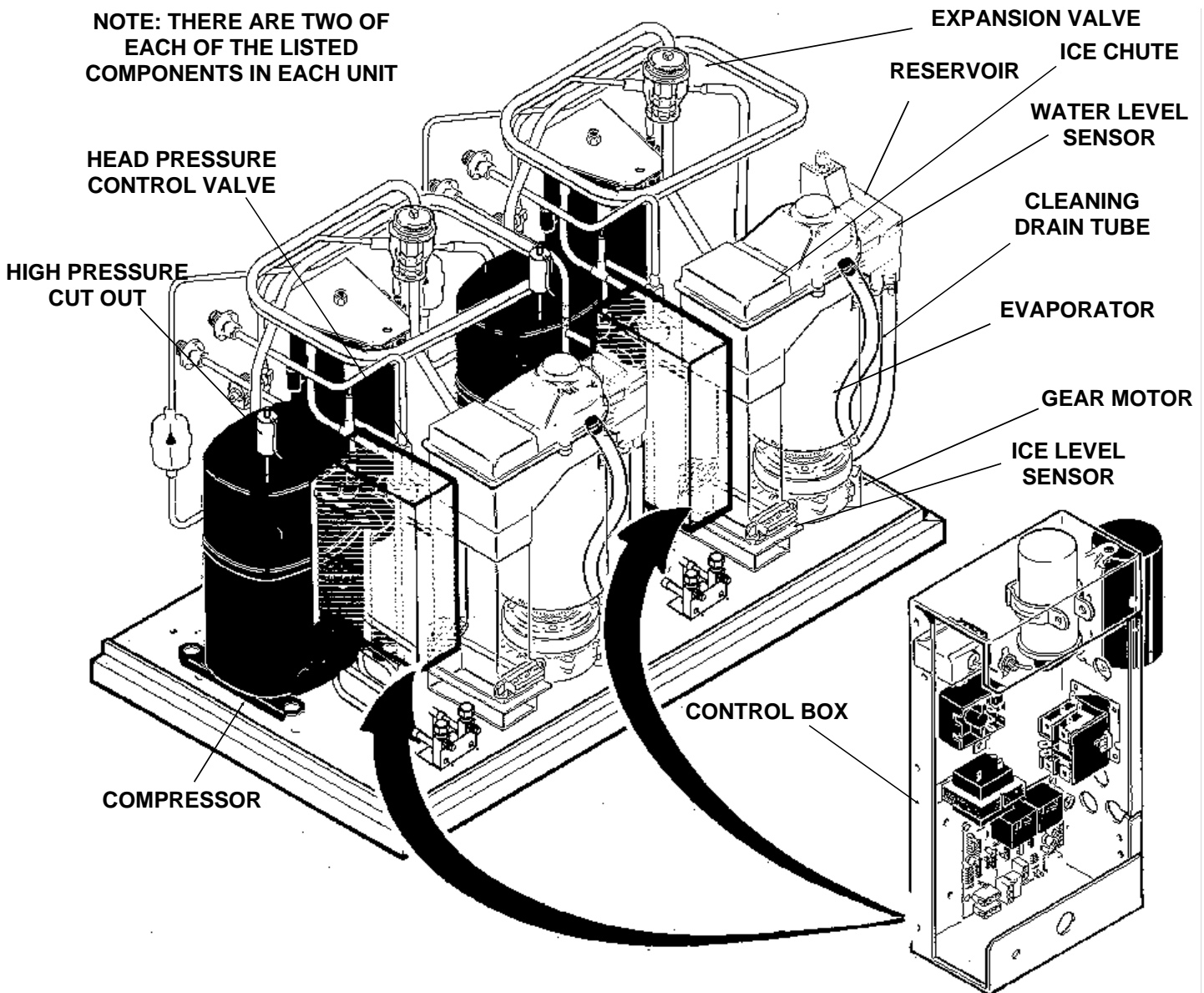

# NME1850R & FME2400R

## COMPONENT DESCRIPTION: Control Box

*There are two control boxes in the machine.*

**Contactor:** A definite purpose contactor connecting the compressor and the remote condenser fan motor to the power supply.

**Circuit Board:** Controlling the ice machine through sensors and relays. The sensors are: ice level, and water level. The relays are for the gear motor (with a built in time delay to clear the evaporator of ice when the unit turns off) and for the liquid line valve.

**Transformer:** Supplies low voltage to the circuit board.

**Pump Down Control:** An automatic reset pressure switch connected to the low side of the refrigeration system. Controls the compressor.

**Potential Relay:** The compressor start relay.

**On/Off Switch:** Manual control for the machine.

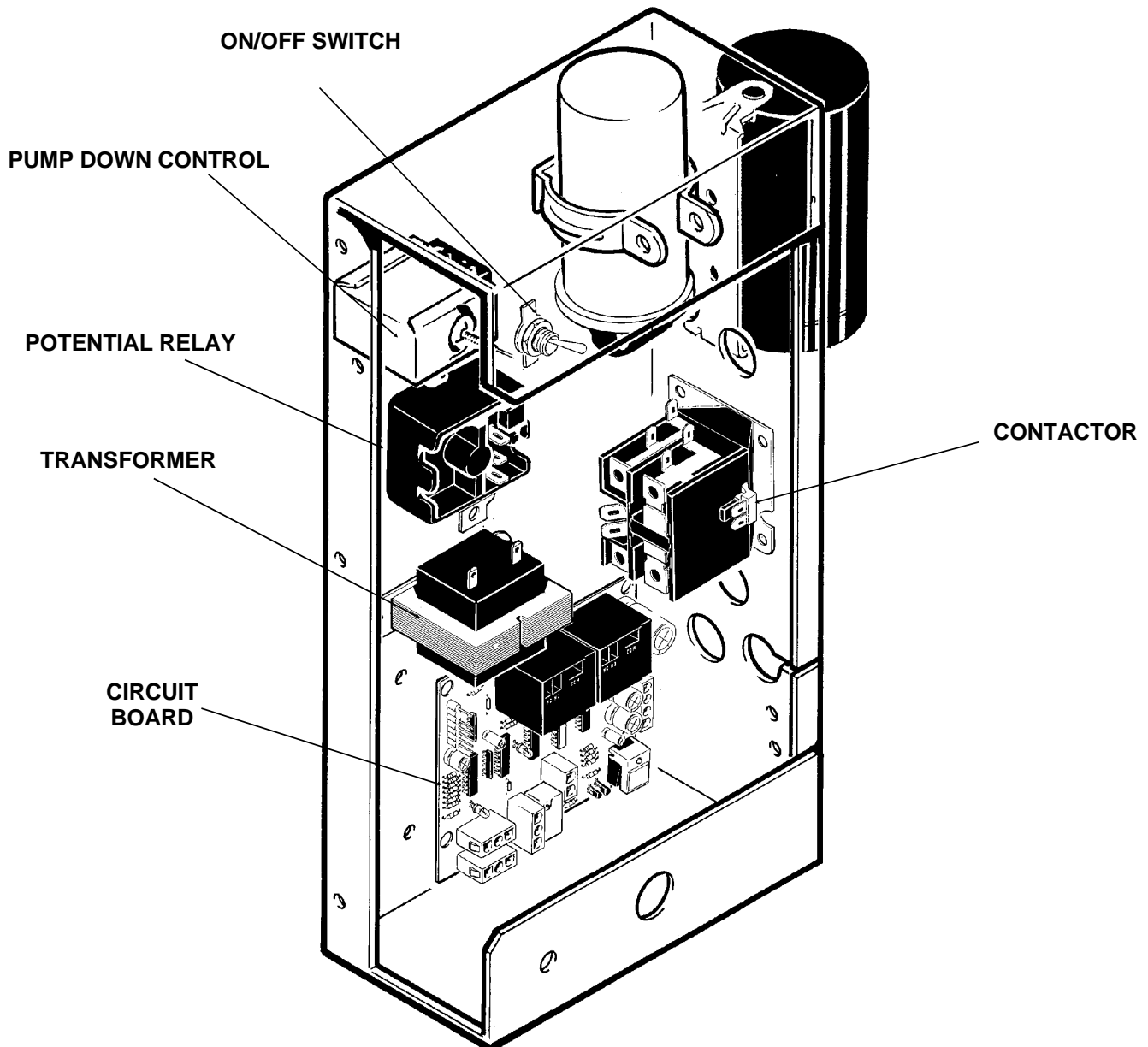

# NME1850R & FME2400R

## ELECTRICAL SEQUENCE

---

Refer the wiring diagram as needed.

The two ice making systems operate independently except for the fan motor of the remote condenser. If either one of the systems is operating, the fan will be ON.

If the machine is switched off at the master switch, but is otherwise ready to go, switching the master switch to ON does the following:

- The bin empty light on the circuit board goes on
- There is a 15 second delay
- If there is enough water in the reservoir, the circuit board will allow the machine to start up.

### **Start up consists of:**

- The liquid line relay and auger motor relay become energized, connecting power to the liquid line solenoid coil and to the windings of the auger motor.
- The liquid line solenoid opens, raising the low side pressure.
- The pump down control closes.
- The auger motor starts, and the centrifugal switch closes, connecting power to the compressor contactor coil.
- The contactor is energized, connecting power to: the compressor and the fan motor relay.
- The fan motor and the compressor start.
- As ice goes past the ice level sensors, the bin empty light will stay on, and the machine will continue to run, unless the ice stays between the sensors for more than 15 seconds (bin full). At that point, the bin empty light goes out, and the machine shuts down.

### **Shut Down consists of:**

- The liquid line solenoid closes, lowering the suction pressure.
- The pump down control opens.
- The compressor contactor opens
- The compressor and fan motor stop (unless the other ice making system is on, then the fan motor stays ON).
- The auger motor is run by the circuit board for 2 more minutes, clearing out ice in the evaporator, and then
- The auger motor relay opens, and the auger motor stops.

If the ice level sensor is clear (bin empty) for more than 15 seconds, the machine will start up again.

Another purpose of the circuit board is to turn the machine off if there is not enough water in the machine.

- When the water level in the reservoir falls below the water level sensor, the machine will "shut down"
- When the water refills the reservoir, the machine will start up again.

Separate from the circuit board:

- The high pressure control will stop the machine immediately if it opens. It is manually reset at the control.
- A master switch is the manual control for each system, but it is not a service disconnect.



## OPERATION: Water

Water enters the machine through the 3/8" male flare at the rear of the cabinet, divides into two inlet lines to each water reservoir which it enters through the float valve. The water then goes out the bottom of the reservoir tanks to the bottom of the evaporators.

Reservoir overflow or evaporator condensation is combined into a common drain line and routed to the drain.

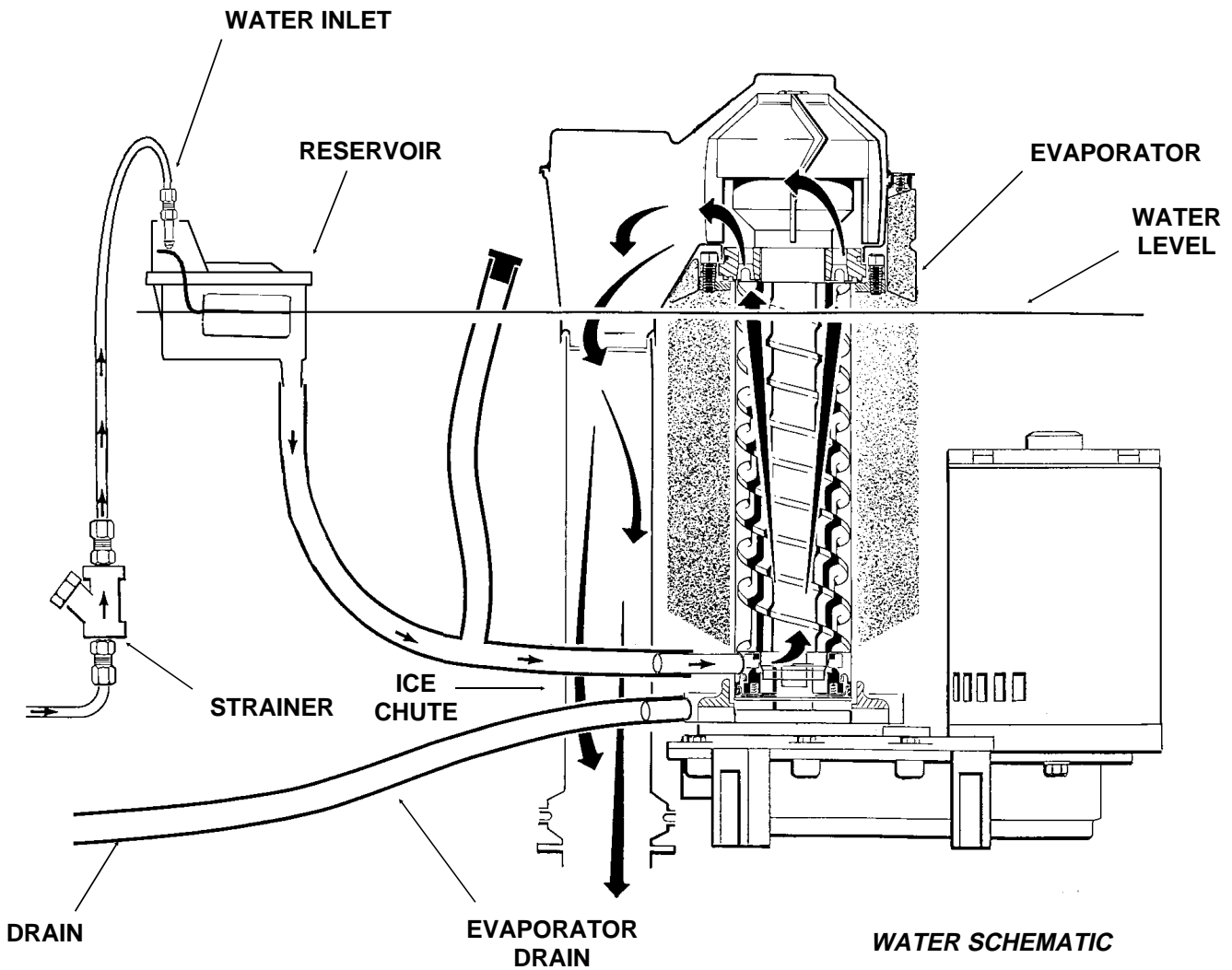

# NME1850R & FME2400R

## OPERATION: Refrigeration

*There are two separate refrigeration systems in this machine.*

Beginning at the compressor, the refrigerant is compressed into a high temperature gas. The discharge line directs this gas to the condenser. At the remote condenser the gas is cooled by air and it then condenses into a liquid. This high pressure liquid then goes through the liquid line to the head pressure control valve, into the receiver, through the liquid line valve and then through the expansion valve.

The thermostatic expansion valve meters liquid refrigerant into the evaporator, the volume of liquid refrigerant depending upon the temperature of the evaporator; warmer evaporators get more refrigerant and colder evaporators get less.

At the evaporator, the refrigerant enters an area of relatively low pressure, where it can easily "boil off" or evaporate. As it evaporates, it absorbs heat from the evaporator and whatever is in contact with it (such as the water inside it). After the evaporator, the refrigerant, now a low pressure vapor, goes through the suction line back to compressor, where the cycle is repeated.

System Information @ 90°F. air and 70°F. Water:

Typical Suction Pressure

- 35 PSIG

Typical Discharge Pressure

- 260 PSIG

Minimum Discharge pressure (low temps)

- 180 PSIG

Typical Compressor Amps

- Single Phase = 4.3
- Three Phase = 2.8

### Refrigeration Schematic

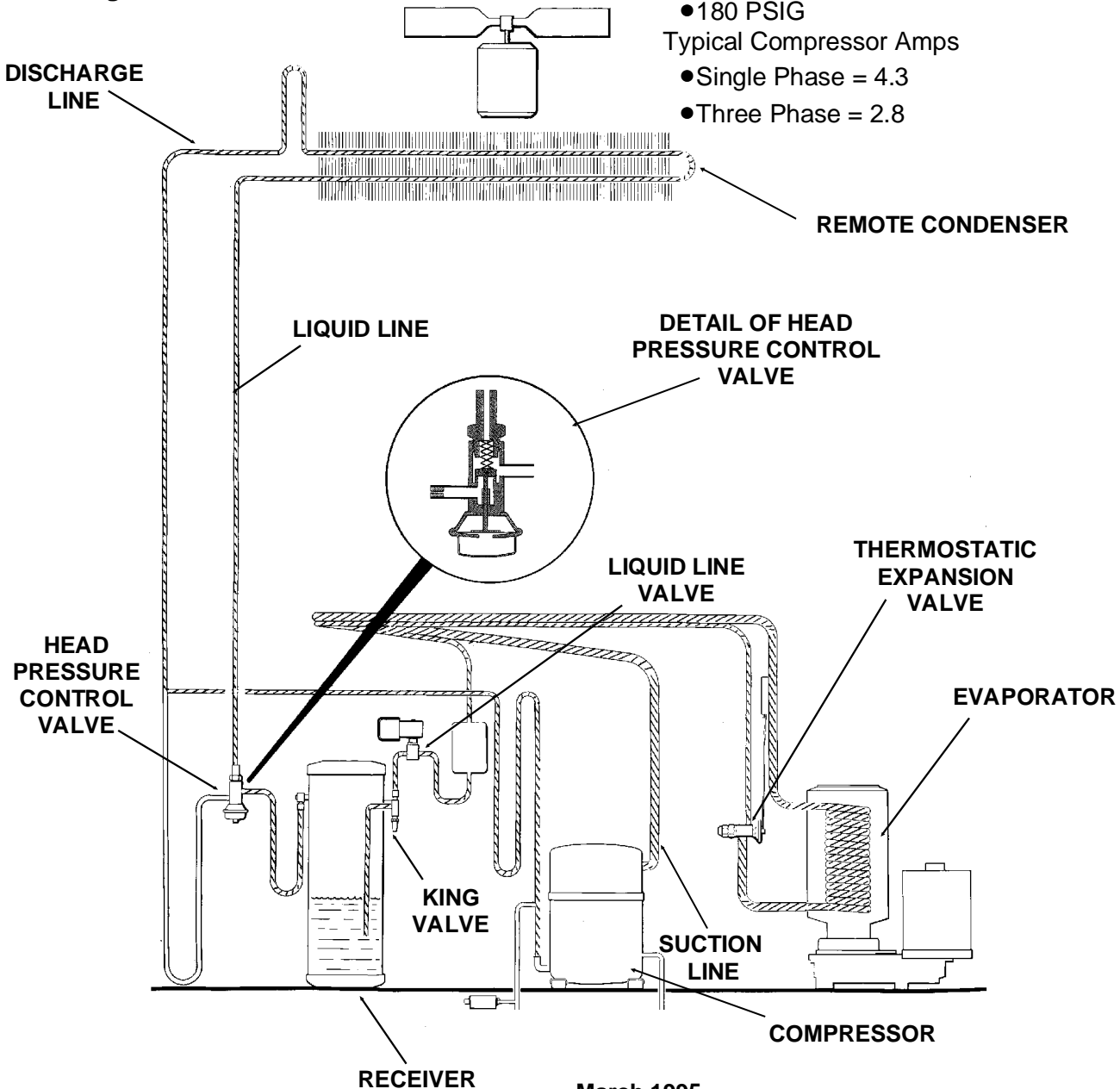

## OPERATION: Refrigeration

*There are two separate refrigeration systems in this machine.*

### Low Condensing Temperature

The refrigeration system under low condenser air temperatures is much the same as it is under higher temperatures, with the exception that the resulting low head pressures cause the head pressure control to close off the liquid line between the condenser and the receiver.

This forces more refrigerant into the condenser (with a small amount of discharge gas going into the receiver to maintain pressure until the head pressure is built back up to the rated gauge pressure of 180 psig). At that pressure the valve opens up the liquid line from the condenser to the receiver.

Head Pressure Control Valve - Low Temperature

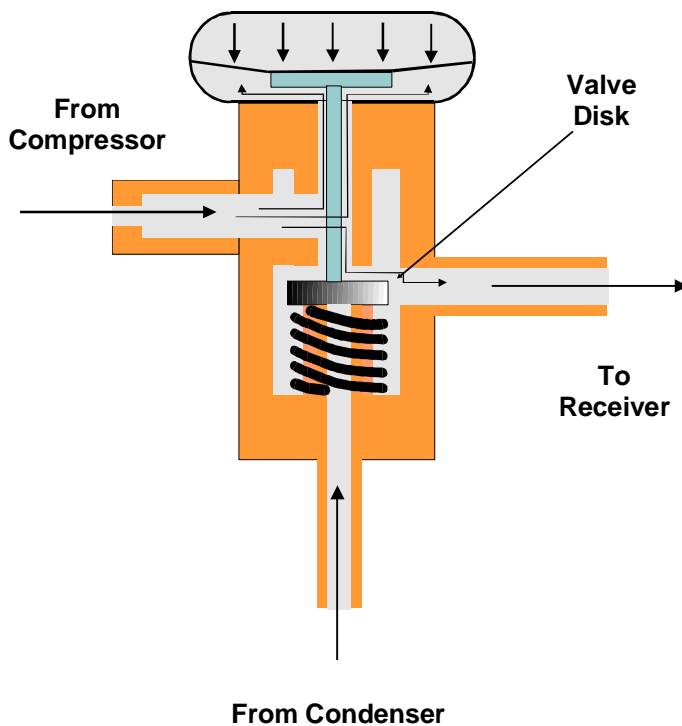

Head Pressure Control Valve - Normal Temperature

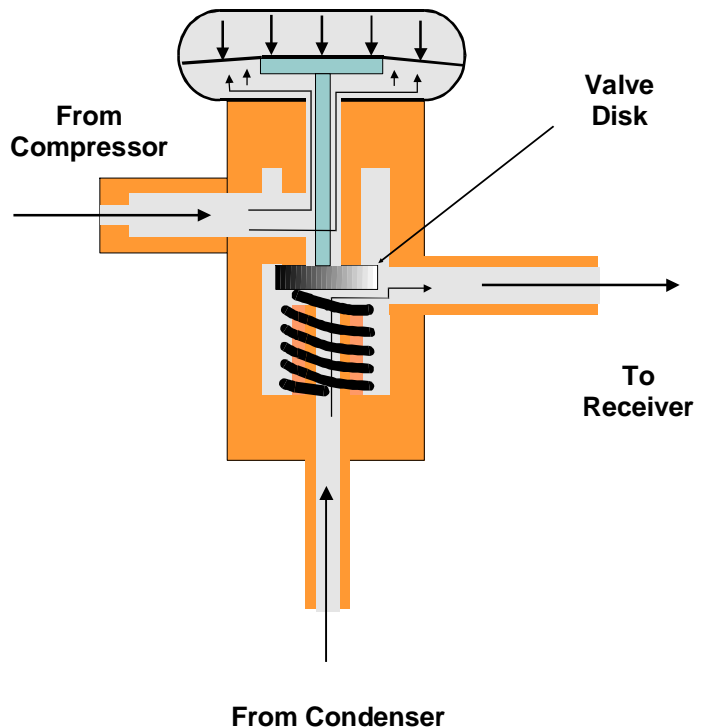

### PUMP DOWN

During the pump down cycle (usually initiated by the circuit board de-energizing the liquid line valve) the discharge gases flow through their normal path to the remote condenser, through the head pressure control, and into the receiver.

At this point the refrigerant flow is stopped by the closed liquid line valve. This action forces the refrigerant into the receiver and keeps it out of the compressor. The pump down continues until the low pressure control turns the compressor off.

# NME1850R & FME2400R

## MAINTENANCE AND CLEANING

*These units consist of **two separate** ice makers; to properly clean and maintain the them, these steps must be followed for **both** systems.*

A Scotsman Ice System represents a sizable investment of time and money in any company's business. In order to receive the best return for that investment, it **MUST** receive periodic maintenance.

It is the **USER'S RESPONSIBILITY** to see that the unit is properly maintained. It is always preferable, and less costly in the long run, to avoid possible down time by keeping it clean; adjusting it as needed; and by replacing worn parts before they can cause failure. The following is a list of recommended maintenance that will help keep the machine running with a minimum of problems.

Maintenance and Cleaning should be scheduled at a minimum of twice per year.

### ICE MAKING SYSTEM: In place cleaning

1. Check and clean any water treatment devices, if any are installed.
2. Remove screws and the front panel.
3. Move the ON-OFF switch to OFF.
4. Remove all the ice from the storage bin.
5. Remove the cover to the water reservoir and block the float up.
6. Drain the water reservoir and freezer assembly using the drain tube attached to the freezer water inlet. Return the drain tube to its normal upright position and replace the end cap.
7. Prepare the cleaning solution: Mix eight ounces of Scotsman Ice Machine Cleaner with three quarts of hot water. The solution should be between 90 and 115 degrees F.

<b>⚠ WARNING</b>	<b>Scotsman Ice Machine Cleaner contains acids. These compounds may cause burns.</b> If swallowed, <b>DO NOT</b> induce vomiting. Give large amounts of water or milk. Call Physician immediately. In case of external contact, flush with water. Keep out of the reach of children.
	

8. Slowly pour the cleaning solution into the water reservoir until it is full. Wait 15 minutes, then switch the master switch to ON.
9. As the ice maker begins to use water from the reservoir, continue to add more cleaning solution to maintain a full reservoir.
10. After all of the cleaning solution has been added to the reservoir, and the reservoir is nearly empty, switch the master switch to OFF.
11. After draining the reservoir, as in step 6, wash and rinse the water reservoir.

12. Go thru steps 13-19 to sanitize the ice machine water system.

13. Mix two gallons of sanitizer solution. Use an approved sanitizer.

A possible sanitizer solution may be obtained by mixing two gallons of warm (90-115°F.) potable water with 1 ounce of household bleach.

14. Slowly pout the sanitizer solution into the water reservoir until the float rises, then switch the master switch ON.

15. As the ice machine uses water from the reservoir, continue to pour the sanitizer solution into the reservoir.

16. After ½ of the sanitizer solution has been added to the reservoir, and the reservoir is nearly empty, switch the master switch OFF.

17. Drain the reservoir and thoroughly wash the interior of the reservoir and cover with sanitizer solution. Be sure the drain hose is upright and capped.

18. Remove the block from the float in the water reservoir.

19. Switch the master switch to ON

20. Continue ice making for at least 15 minutes, to flush out any cleaning solution.

**DO NOT USE any ice produced from the cleaning solution. Be sure no ice remains in the bin.**

21. Remove all ice from the storage bin.

22. Add warm water to the ice storage bin and thoroughly wash and rinse all surfaces within the bin.

23. Sanitize the bin interior by washing the interior of the bin with the balance of the sanitizer solution.

24. Switch the master switch ON.

## MAINTENANCE AND CLEANING

These units consist of **two separate** ice makers; to properly clean and maintain them, these steps must be followed for **both** systems.

	<p><b>⚠ WARNING</b></p> <p>Disconnect electrical power before beginning.</p>
---	--

1. The bin control uses devices that sense light, therefore they must be kept clean enough so that they can "see". At least twice a year, remove the bin control sensors from the base of the ice chute, and wipe the inside clean, as illustrated.
2. The ice machine senses water level by a probe located in the water reservoir. At least twice a year, the probe should be removed from the reservoir, and the tip wiped clean of mineral build-up.

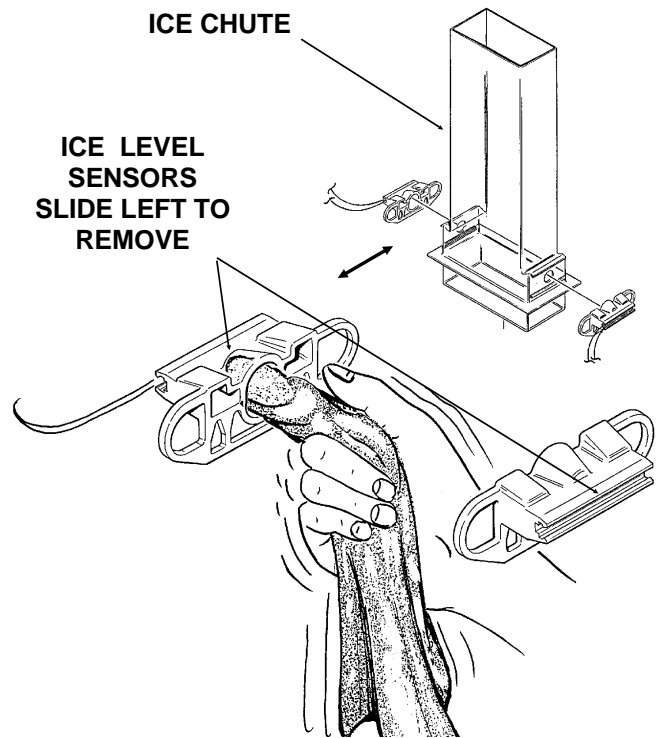

- Inspect the assembly, looking for wear
4. Clean the remote condenser. Use a vacuum cleaner or coil cleaner if needed. Do NOT use a wire brush.
  5. Check and tighten all bolts and screws.

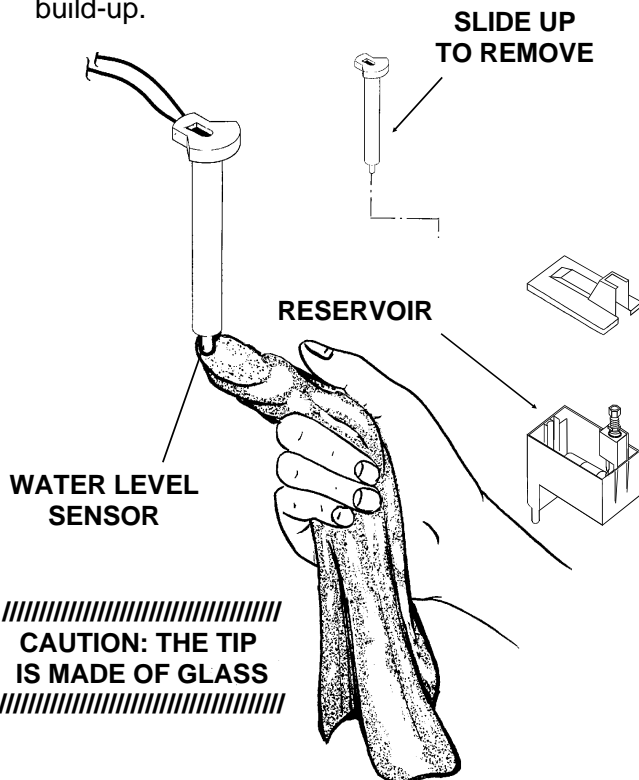

3. The top bearing in the breaker should also be checked at least **two times per year**.

Check the breaker bearing by:

- removing the ice chute cover
- unscrewing the ice sweep
- removing the water shed
- unscrewing the breaker cover (left hand thread)
- unscrewing the auger stud

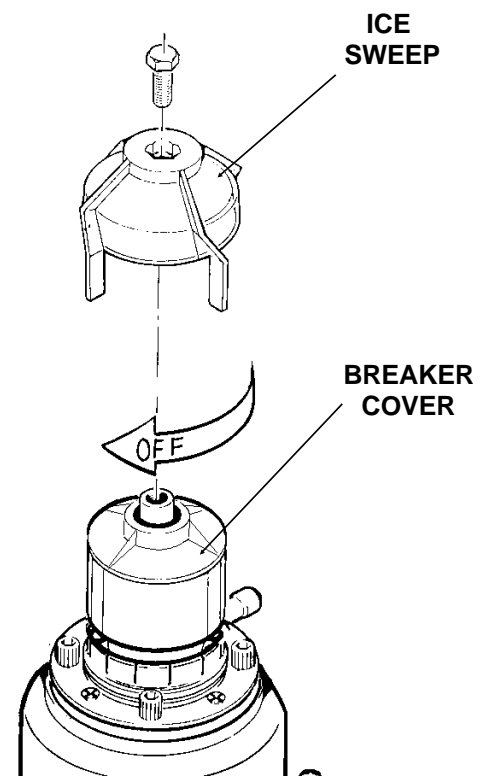

# NME1850R & FME2400R

## MAINTENANCE AND CLEANING

---

In some areas the water supply to the ice maker will have a great deal of minerals in it, and that will result in an evaporator and auger becoming coated with these minerals, requiring a more frequent removal than twice per year. If in doubt about the condition of the evaporator and auger, the auger can be removed so the parts can be inspected.

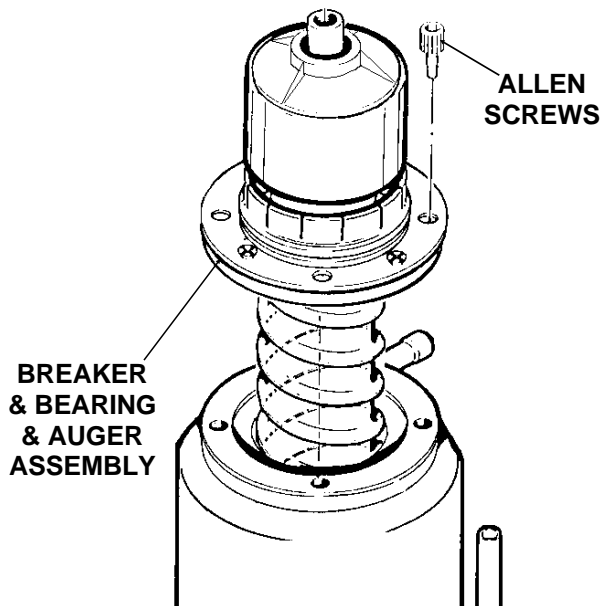

Note: Water filters can filter out suspended solids, but not dissolved solids. "Soft" water may not be the complete answer. Check with a water treatment specialist regarding water treatment

***For more information on removal and replacement of these parts, see REMOVAL AND REPLACEMENT.***

### **Shut off water and electrical supply.**

1. To remove the auger, remove the front and top panels.
2. Push back bail clamp holding ice chute cover to ice chute, and remove cover.
3. Unscrew and remove ice sweep.
4. Loosen band clamp under ice chute, and remove ice chute from evaporator.
5. Remove 4 allen screws holding breaker to evaporator.
6. Pull up to remove auger.

After the auger has been removed, allow the auger to dry; if the auger is not bright and shiny, it must be cleaned.

Clean the auger and evaporator as required.

**DO NOT HONE THE EVAPORATOR.**

7. Replace the water seal.
8. Reverse to reassemble.

# NME1850R & FME2400R

## SERVICE DIAGNOSIS: Condition - No Ice Being Produced

---

### STATUS: *NOTHING OPERATES*

---

**A.** Check: **Voltage** to the unit, restore it if there is none. Compare to the nameplate.

---

**B.** Check: The **master switch**, switch ON if off.

---

**C.** Check: The reset switch (high pressure): depress and release the switch. If the unit still does not start, check the spout switch, or high side pressure.

---

**D.** Check the **high pressure cut out switch**, if closed, go to E; if open:

1. This pressure switch opens at 450 psig. Check the high side pressure, reset the switch and observe that the fan is forcing air through the condenser. If the switch opens at pressures below 400 psig, replace the switch. If the pressures rise above the trip out point, and the unit shuts down:

a. Check for adequate air flow. Clean the condenser. If the air flow is poor because of the installation, advise the user that the unit should be moved, or the air around it kept cooler.

Check the fan motor for tight bearings and proper rotation.

Check that the fan blades are clean, and the fan secure to the fan motor shaft.

b. Check the head pressure control valve, it should be maintaining a head pressure above 220 psig. If the unit has the correct charge, and the condenser is clean, and the refrigerant lines are not kinked or twisted, and the condenser is not overheated by external heat loads, the head pressure should be under the trip out point of the head pressure control switch. If all of the above are found to be good, and the machine trips out on high head pressure, replace the head pressure control valve.

---

**E.** Check the **water level**. If there is not enough water in the reservoir, the water level sensor will keep the machine from starting.

a. Check the water level, restore/adjust if low.

b. Check the water level sensor, clean if dirty, (see maintenance).

c. Check the circuit board, see next page.

If the machine does not start, see the next page.

# NME1850R & FME2400R

## SERVICE DIAGNOSIS: Condition - No Ice Being Produced

---

### STATUS: *NOTHING OPERATES*

---

**F. Check:** The gear **motor**, if it will not run, the compressor will not run. If no power to it: Check: the **indicator lights** on the circuit board, the **bin empty** light should be ON, the **no water** light should be OFF .

1. If the **bin empty** and **no water** lights are off, check the **transformer**.
  - a. Transformer "load" side should have 12 to 15 volts. If not, check the "line" side. The line side should have between 208-230 volts. If the line side has the correct voltage and the load side does not, replace the transformer.
2. If the transformer is good, and the **bin empty** light is OFF, check the **ice level sensors**.
  - a. Remove sensors by sliding them sideways out of the ice chute. Visually inspect them, clean if needed.
  - b. Look through the ice chute "eye" hole for something blocking the ice chute.
  - c. If the unit still does not run, replace the ice level sensors.
  - d. If the bin empty light is still OFF, check the **circuit board**.
    1. Unplug "opto trans" and "LED" connectors from the circuit board.
    2. Plug "opto trans" and "LED" connectors from the Scotsman Electronic Control Tester into the circuit board.
      - a. Move the "bin full" switch on the tester to the full position. The bin full light on the tester should be ON, if not, replace the circuit board. If the bin full light on the tester is ON, move the tester switch to "bin empty" the light on the tester should go OFF and the bin empty light on the circuit board should go ON. If not, replace the circuit board. If it does as above, and the machine still does not run, replace the ice level sensors.
3. If the transformer is fine, and the "no water" light is ON, check the **water level sensor**.
  - a. Check the water level in the **reservoir**, restore if low. If the water level is ok:
  - b. Remove the water level sensor from the reservoir and clean the tip if dirty.  
////////////////////////////////////  
**CAUTION: THE TIP IS MADE OF GLASS**  
////////////////////////////////////
  - c. Replace the water level sensor. If the no water light is still on, check that the "water sen" plug is firmly plugged into the circuit board.
  - d. If the no water light is still on,
    1. Unplug the "water sen" connector from the circuit board.
    2. Plug "water sen" connector from the control tester into the circuit board.
      - a. Move the water switch on the tester to "no water" and the no water light on the circuit board should go on. If not, replace the board..
      - b. Move the water switch to the " water" position, the no water light should go off, if not, replace the circuit board.
      - c. If after the above, the machine still will not run, replace the water level sensor

MORE INFORMATION ON THE TESTER MAY BE FOUND AT THE END OF THE MANUAL.



# NME1850R & FME2400R

## SERVICE DIAGNOSIS: Condition - No Ice Being Produced

---

*(Work on each system separately)*

### **STATUS: GEAR MOTOR OPERATES, COMPRESSOR DOES NOT**

---

#### **A. Check the pump down control switch.**

1. This pressure switch opens at 15 psig, and closes at 30 psig. If open check the low side pressure, if after running the machine the switch opens at a pressure higher than 18 psig, replace the switch. If the liquid line solenoid valve is open, the low side pressure should be above 30 psig, and the pump down (low pressure) control should be closed. If the low side pressure is below 30 psig:

a. Check if the **auger** is turning, if it is not, remove the **gearbox** and:

Check for internal damage, repair and replace in the machine.

b. Check for low charge, add some refrigerant, if the unit begins to operate, (normal low side pressure being about 32 psig) stop and look for a leak, recover, repair, replace the drier, evacuate, and weigh in the nameplate charge. If, with added charge, the unit does **not** operate:

Check for a restricted system, recover, replace the drier, evacuate, and weigh in a nameplate charge.

Check for a **Thermostatic Expansion Valve** that does not open, if defective, replace it. Recover, replace the drier, evacuate, and weigh in the nameplate charge.

c. Check the liquid line solenoid valve, it should have power to it, if not:

Check the connections on the circuit board. The liquid line (or compressor) relay on the circuit board may have failed. If so, replace the circuit board.

If there is power to the valve, the coil may be open, or the valve jammed, replace the valve

Note: Pump down control Cut In and Cut Out changed in May 1995. It was CI= 17, CO=2..

# NME1850R & FME2400R

## SERVICE DIAGNOSIS: Condition - Low Ice Production

---

### **STATUS: *EVERYTHING IS OPERATING***

---

**A.** Check the condenser for dirt. Clean as required. Check the head pressure. If the head pressure is very high:

1. Check for high air temperatures, or restrictive air flow. Correct as needed.
  2. The refrigerant may contain non condensable gases, recover, evacuate, and recharge per nameplate.
  3. Check the interconnecting refrigerant tubing for kinks or twists.  
Check that the discharge and liquid lines are insulated, and do not touch each other where not insulated.
- 

**B.** Check the evaporator

1. Clean the evaporator, the mineral build up will adversely affect the ice machines production.
  2. Check the evaporator for water leaks, replace the water seal if found to be leaking.
  3. Check the low side pressure; normal is about 32 psig. If low, assume a refrigerant leak, locate, recover, repair and recharge.  
If no leak, the TXV may be restricted, defective or not adjusted properly. If needed, replace the TXV, evacuate, and recharge per nameplate.
  4. Check the insulation on the evaporator. It should be dry, with no wet spots or frost. If the insulation has failed: replace the evaporator or add extra insulation in the form of foam tape to the evaporator.
- 

**C.** Check the compressor

1. The compressor may be inefficient.
    - a. Check the amp draw, if low change the compressor.
    - b. if the amp draw is normal, pinch off the suction line to check the pull down capability of the compressor. The compressor should pull down to 25 inches of vacuum and hold there for three to five minutes.
- 

**D.** Refrigerant charge

On this model the refrigerant charge is adequate whenever the receiver has enough liquid refrigerant to maintain liquid refrigerant at the TXV. HOWEVER, the condensing temperature will have a definite bearing on this. A unit with a marginal charge in summer, will be **undercharged** when the outside air temperature drops. The only correct way to charge this unit is to weigh in the nameplate charge.

# NME1850R & FME2400R

## REMOVAL AND REPLACEMENT: Water Reservoir & Bin Controls

### WATER RESERVOIR

1. Shut off the water supply to the ice maker.
2. Remove front panel and reservoir cover.
3. Disconnect water inlet tube from reservoir inlet fitting.
4. To remove float valve, push in "locking tabs" as shown and pull float up.  
Note: The plunger/seat is available separately as a part.
5. To remove reservoir, pull up and remove water sensor.
8. Disconnect water outlet tubes.
9. Remove mounting screws from reservoir bracket and remove the reservoir from the ice maker.
10. Reverse to reassemble.

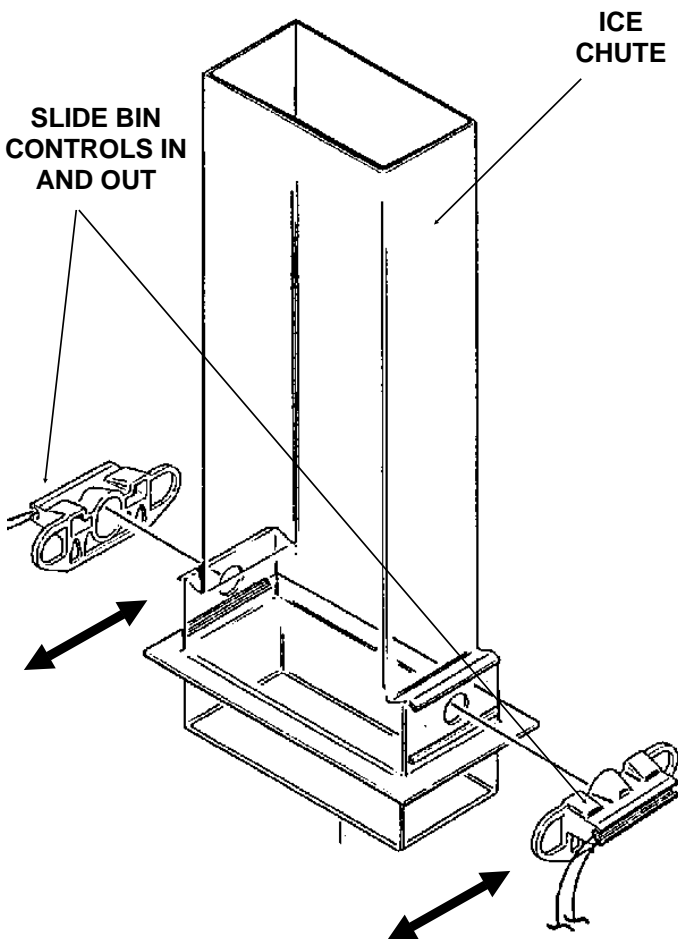
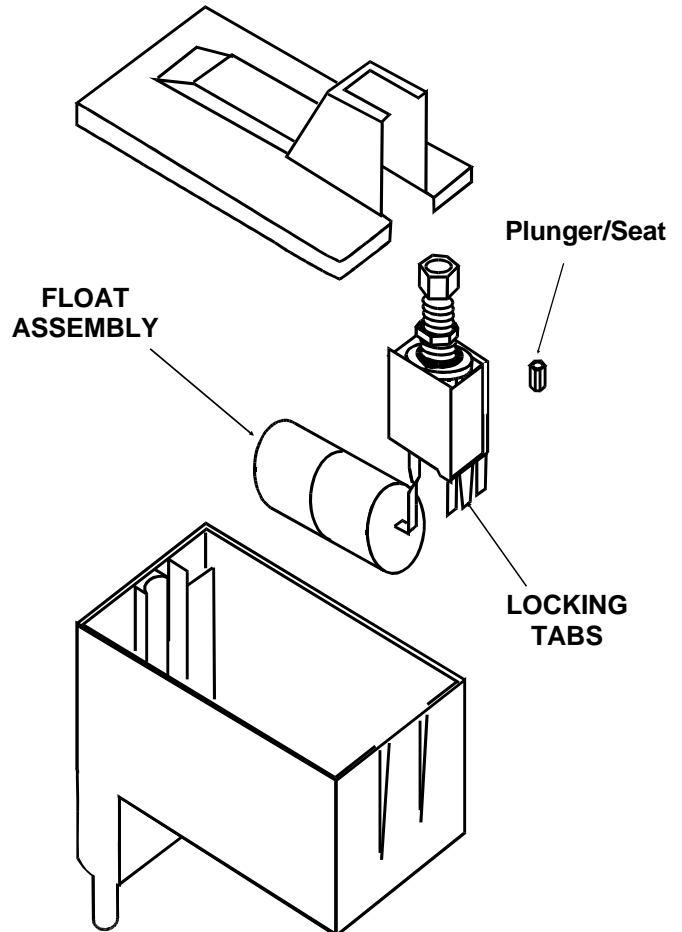

### BIN CONTROLS (Ice Level Sensors)

1. Disconnect electrical power.
2. Remove front panel.
3. Remove control box cover.
4. Locate ice chute, at the base of the chute, in front of and behind it are two plastic bin control mounts.
5. Slide each bin control to the left, and in the control box, disconnect the electrical leads connecting the bin control to the circuit board.
6. Reverse to reassemble, be certain that the bin controls are aligned so that the ice level sensors are visible (centered) through the holes in the ice chute.

# NME1850R & FME2400R

## REMOVAL AND REPLACEMENT: Bearing And Breaker

Note: Removal of the auger, water seal, evaporator and gear motor must begin at the top of the assembly.

### To Remove the Breaker Bearing Assembly:

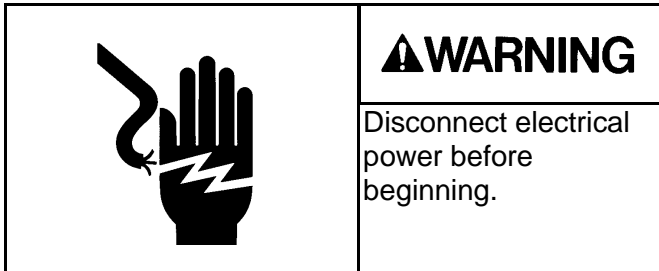

1. Remove panels and disconnect electrical power.
2. Push back bail clamp and remove ice chute cover.
3. Unscrew and remove ice sweep.
4. Remove insulation halves from outside of ice chute, loosen band clamp under ice chute, lift up and remove ice chute.
5. The breaker may be removed from the auger and evaporator without disturbing the auger.
  - a. Unscrew breaker cover from breaker (left hand threads)
  - b. Unscrew auger stud from top of auger.

- c. Unscrew 4 allen head cap screws holding breaker to evaporator.
  - d. Lift up, and remove breaker/bearing assembly from auger & evaporator.
6. Service the bearing. Check for rust, rough spots and damage.
- a. The bearing is pressed into the breaker, to remove the bearing and replace it an arbor press is needed.
  - b. Replace lower seals before installing new bearing in breaker.

Note: seals must be pressed in with a tool pushing against the outer edge only, they will not install by hand.

Replace parts as required. Re-grease bearing with Scotsman part no. 19-0609-01 bearing grease. Replace top seal, and check the o-rings, replace if cut or torn.

7. Reverse to reassemble: specific tools and materials are required to install properly.
- a. Add food grade grease such as Scotsman part number 19-0569-01 to the seal area before installing on the auger.
  - b. Check the seal to shaft areas for cuts, or rough spots: none are permitted.

Note: Flaker parts are shown in this manual. Nugget (NME) breakers do **not** have a Slotted Collar.

Step 5-a

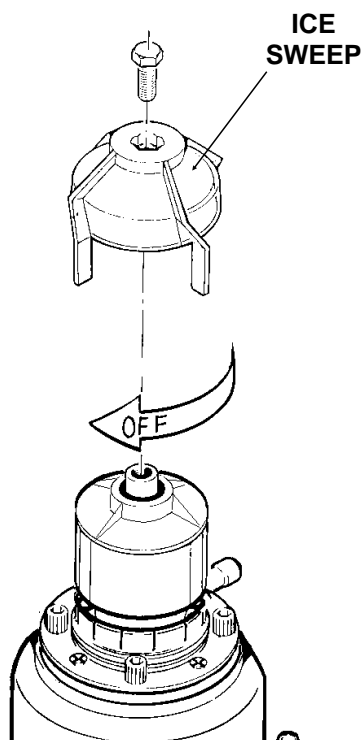

Step 5-b

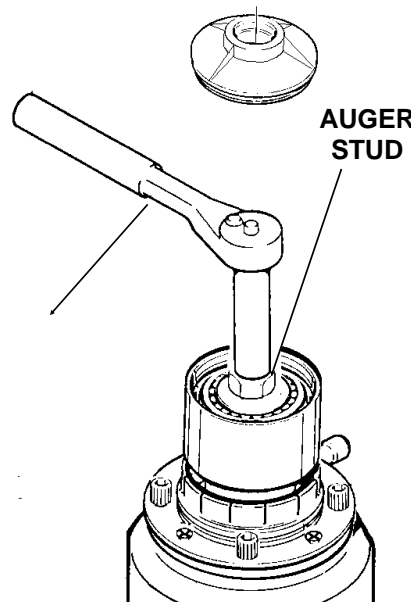

Step 5-c and Step 6

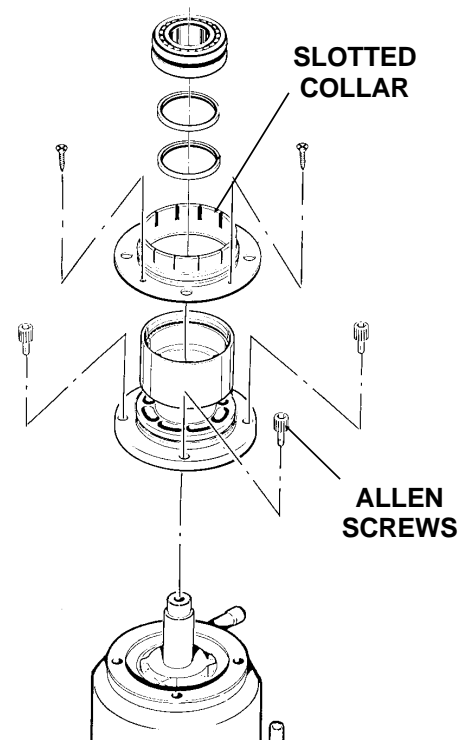

# NME1850R & FME2400R

## REMOVAL AND REPLACEMENT: Auger

Note that the auger has very sharp edges.

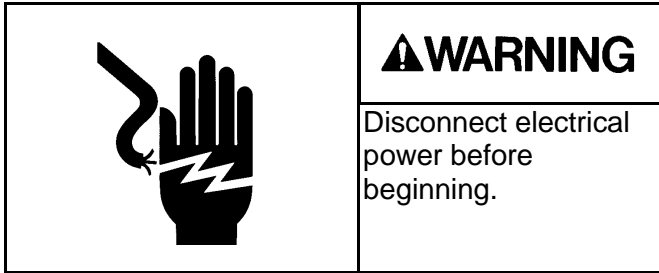

### To Remove the Auger:

Turn off the water to the machine, and unclip the evaporator drain hose, pull it down and drain the evaporator into the bin or a container.

1. The top panel must be removed, or, if that is not possible, the gear motor and freezer assembly must be pulled part of the way out from the cabinet. To do that:

a. Unclip the electrical wires from the hanger near the drive motor.

b. Remove the bolt holding the gear motor plate.

c. Pull the assembly out.

2. The auger and breaker/bearing may now be removed as an assembly.

a. Unscrew 4 allen head cap screws holding breaker to evaporator.

b. Lift up on breaker and remove auger from evaporator.

**Note: If the auger is stuck, the breaker must be removed from the auger.**

The breaker may be removed from the auger and evaporator without disturbing the auger.

a. Unscrew breaker cover from breaker (left hand threads)

b. Unscrew auger stud from top of auger.

c. Unscrew 4 allen head cap screws holding breaker to evaporator.

d. Lift up on breaker to remove from auger.

If the auger is stuck:

Use a slide hammer type puller to pull on the auger at the threaded hole. The size of that hole is 5/8"-18.

Inspect the auger, the critical areas of the auger are:

a. The auger body. It should be clean and shining. Sometimes an auger will appear clean when wet, but after it is dry it will be seen to be stained. Scrub the auger with ice machine cleaner and hot water.

### WARNING

Ice machine cleaner is an acid. Handle it with extreme care, keep out of reach of children.

b. The water seal area. Because the auger has been removed, the water seal will have to be replaced. Remove the water seal top half from the auger, and inspect the auger for minerals clean as required.

*Note: Repeat the above for each evaporator.*

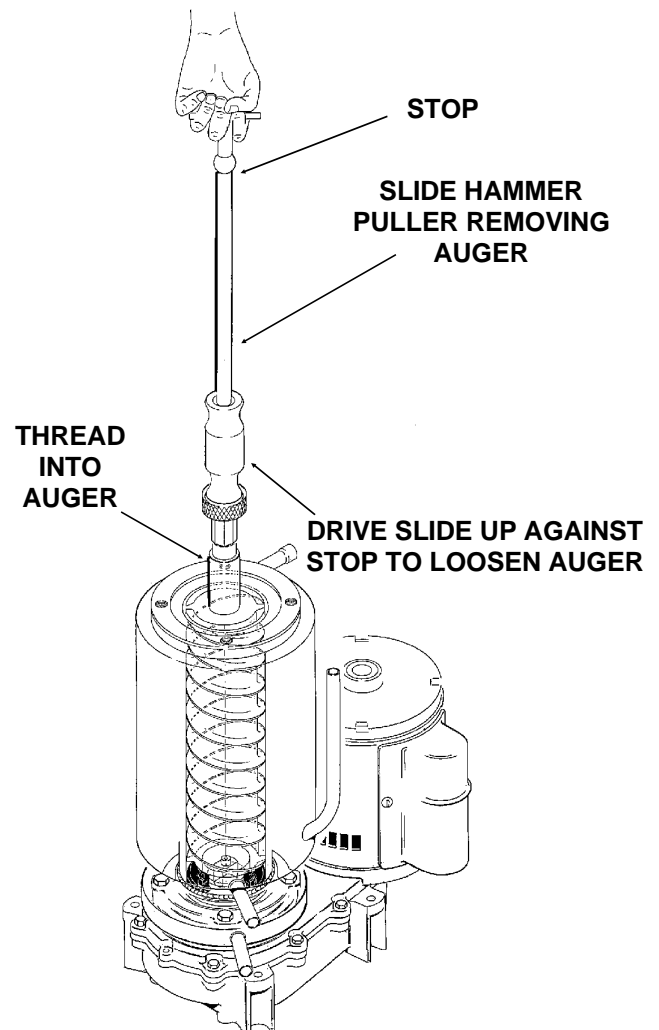
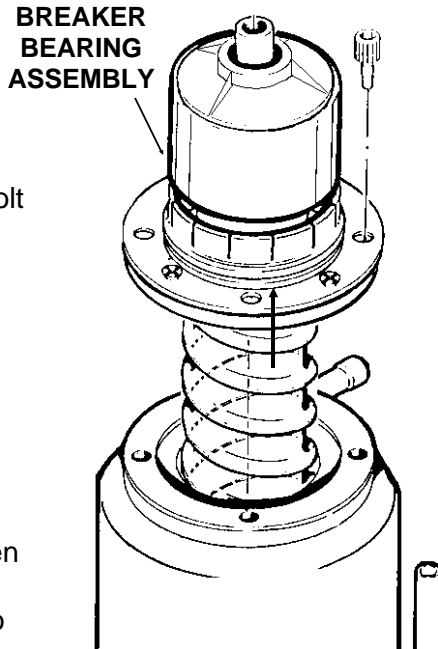

# NME1850R & FME2400R

## REMOVAL AND REPLACEMENT: Water Seal

### To Remove the Water Seal:

(Assuming all steps to remove the auger have been performed.)

1. The gear motor/evaporator assembly will have to be exposed (if not yet done).
2. Remove the 4 hex head cap screws holding the evaporator to the gear motor assembly. Lift the evaporator up and off of the gear motor.
3. Remove the snap ring or wire retainer from the groove under the water seal.
4. Pull or drive out the lower half of the water seal.

### To Replace the Water Seal:

1. Lubricate the water seal with water, and push the water seal into the bottom of the evaporator slightly past the groove for the snap ring.
2. Replace the snap ring and pull the water seal down against it.
3. The part of the water seal that rotates with the auger must also be replaced. Remove the old part from the auger and clean the mounting area.
4. Place a small bead of food grade silastic sealant (such as 732 RTV or Scotsman part number 19-0529-01) on the area of the auger where the water seal is to be mounted.
5. Carefully push the water seal (rubber side against the auger shoulder and the silastic.)

### CAUTION

Do not get any silastic onto the face of the seal.

6. Allow the auger and seal to air dry until the silastic is dry on the surface.

7. If the original water seal was leaking, it would be a good idea to inspect the interior of the gear motor.

### REMOVAL OF THE WATER SEAL

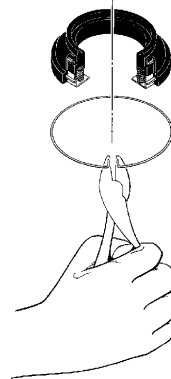
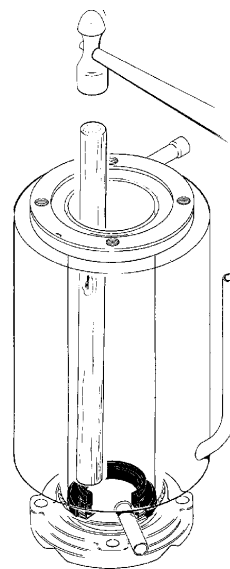

WATER SEAL

RETAINING RING

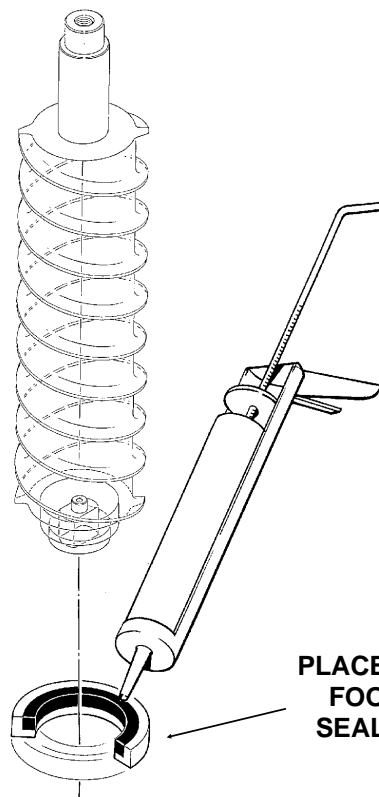

PLACE A BEAD OF FOOD GRADE SEALANT HERE

## REMOVAL AND REPLACEMENT: Evaporator

Shut off the water supply before beginning.

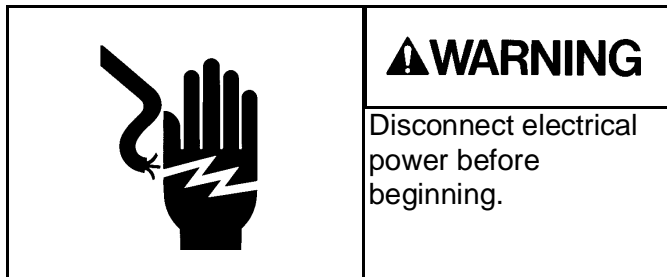

### To Replace the Evaporator:

(Assuming all the steps for removal of the thrust bearing, breaker, auger, and water seal have been performed.)

1. Discharge the refrigerant from the ice maker.
2. Unsweat the refrigerant connections:
  - a) At the thermostatic expansion valve outlet.

-----  
**CAUTION**  
 -----

**Heat sink the TXV body when unsweating or resweating the adjacent tubing.**

-----

- b) At the suction line at the joint about 3" from the evaporator.
3. Disconnect the water inlet tube, and remove the evaporator.
4. Unsweat the drier from the liquid line.

*Repeat the above, as required, for each system.*

5. After installing a new water seal in the new evaporator ( see "To Replace the Water Seal") resweat the tubing connections.
6. Install an new drier in the liquid line.
7. Evacuate the system until dehydrated, then weigh in the nameplate charge. Check for leaks.
8. Install auger, breaker, breaker bearing assembly, and ice discharge chute in reverse order of disassembly. See "To Reassemble Evaporator and Auger"

### To Reassemble the Evaporator and Auger

1. After the gear motor has been inspected, fasten the evaporator to the gear motor, be sure that the number of shims indicated on the gear case cover is in place between the gearcase cover and the drip pan gasket. Torque the bolts to 110 inch pounds.
2. Lower the auger into the evaporator barrel, slightly turning it to match up with the drive end. Do Not Drop Into the Evaporator.
3. Complete the reassembly by reversing the disassembly for the breaker & thrust bearing assembly.

### Head Pressure Control Valve

1. Purge system of refrigerant
2. Break off process tube on the top of the OLD head pressure control valve.
3. Unsweat old valve from tubing.
4. Unsweat old dryer from tubing.
5. Install new valve in place, check for correct connections and be sure the number on the side of the valve is "180"
6. Wrap the new valve body in wet cloths to heat sink the valve body.
7. Sweat in the new valve and the new dryer.
8. Evacuate the system, and weigh the nameplate charge into the receiver.

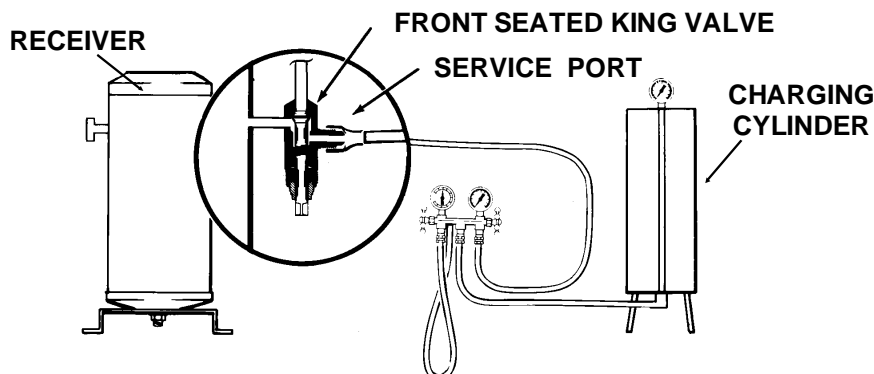

### Charging Procedures

Extra care must be taken when recharging this remote system. No liquid refrigerant may be placed in the system at the compressor. DO NOT use the access valves at the front of the unit for weighing in the charge. All liquid R-404A must be weighed into the receiver through the "front seated" king valve.

# NME1850R & FME2400R

## REMOVAL AND REPLACEMENT: Gear motor Assembly

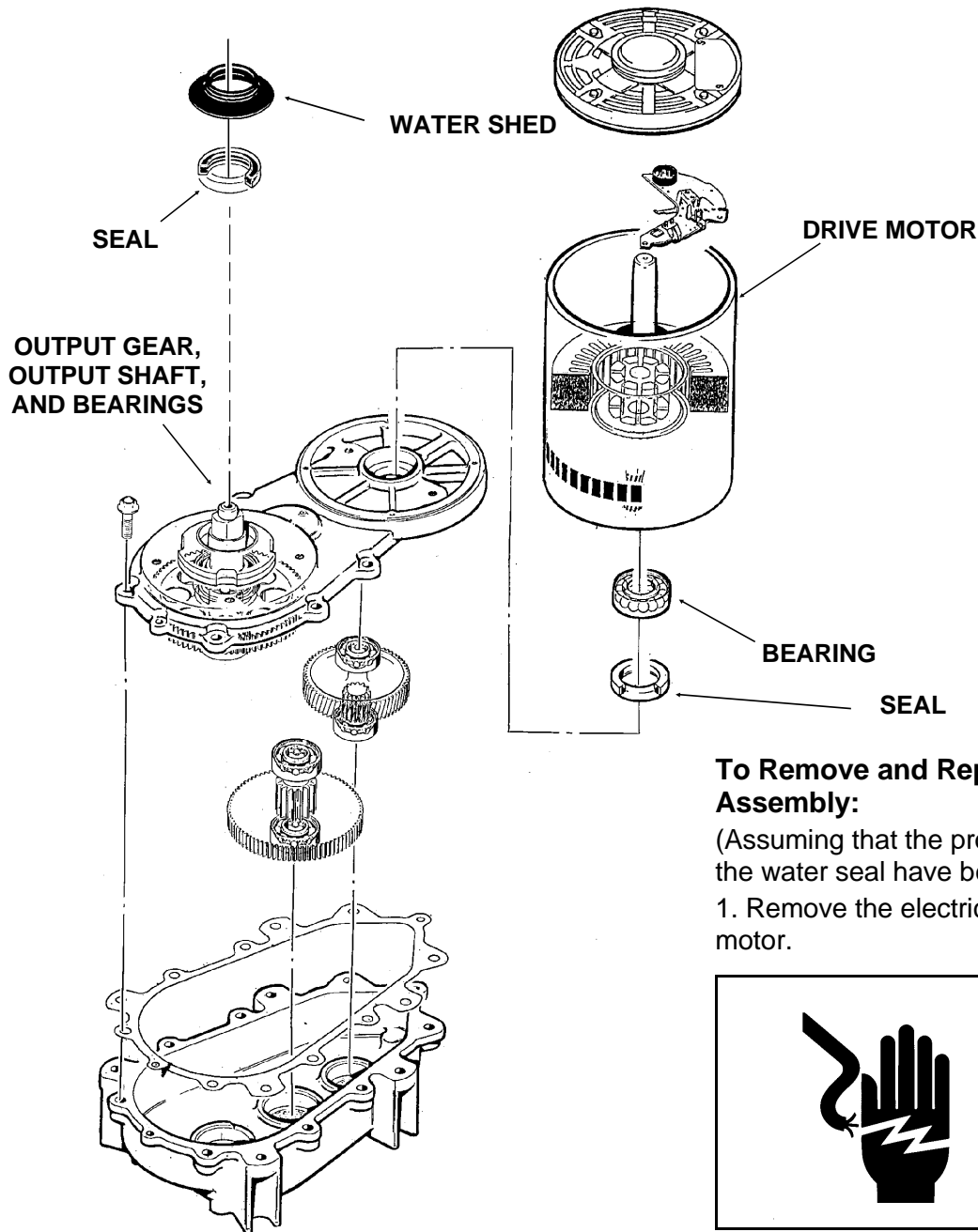

**Note:** There are two gear motors in each unit.

### To Remove and Repair the Gear motor Assembly:

(Assuming that the procedures through removal of the water seal have been performed.)

1. Remove the electrical wires from the gear drive motor.

	<b>▲WARNING</b>
	Disconnect electrical power before beginning.

2. Unscrew the 4 cap screws holding the gear motor to the gear motor plate.
3. Remove the gear motor from the ice maker.

### To Inspect the gear motor.

- A) Remove the cap screws holding the gear motor case halves together and pry the two cases apart.
- B) To lift off the cover, lift up until you can feel internal contact, then pull the cover towards the output gear end, and then lift the cover (with drive motor attached) up and away from the gear motor case.

Note: The case cover output gear, bearings, and shaft are one pressed together assembly.



# NME1850R & FME2400R

## REFRIGERATION SYSTEM SERVICE

### General:

This ice machine uses R-404A (HP62) refrigerant and polyolester oil. Do NOT use mineral oil in this refrigeration system.

- R-404A is a "Near Azeotrope" so liquid charging is required:
- When the system is serviced, a special liquid line drier is required. It is included with replacement compressors.
- HP62 is not compatible with mineral oil, so these ice machines use Polyolester oil. Polyolester oil absorbs water very easily. When one of these refrigeration systems is opened for service, it must be re-sealed as soon as possible (15 minutes maximum).
- Special leak detection equipment is required to locate small refrigerant leaks. Usually a leak detector capable of detecting a Halogenated refrigerant or HFC-134a will work. Check with the leak detector manufacturer if in doubt.

Access Valves: To use the access valves:

- Remove the cap from the stem, use a 3/16" allen wrench to check that the valve is CLOSED. Then remove the core cap.
- **Close the valve and replace the caps when the job is finished. The valve must be closed and the caps must be on or the valve will leak.**

### Pressure-Temperature Chart for HP62

VAPOR		VAPOR	
TEMP. (DEG F)	PRESS. (PSIG)	TEMP. (DEG F)	PRESS. (PSIG)
-20	17	70	146
-18	18	72	150
-16	20	74	155
-14	21	76	161
-12	23	78	166
-10	24	80	171
-8	26	82	177
-6	28	84	182
-4	29	86	188
-2	31	88	194
0	33	90	200
2	35	92	206
4	37	94	212
6	39	96	219
8	41	98	225
10	43	100	232
12	46	102	239
14	48	104	246
16	50	106	253
18	53	108	260
20	55	110	268
22	58	112	275
24	60	114	283
26	63	116	291
28	66	118	299
30	69	120	307
32	72	122	316
34	75	124	324
36	78	126	333
38	81	128	342
40	85	130	351
42	88	132	360
44	91	134	370
46	95	136	379
48	99	138	389
50	102	140	399
52	106	142	409
54	110	144	420
56	114	146	430
58	118	148	441
60	123	150	452
62	127	152	464
64	132	154	475
66	136	156	487
68	141	158	499

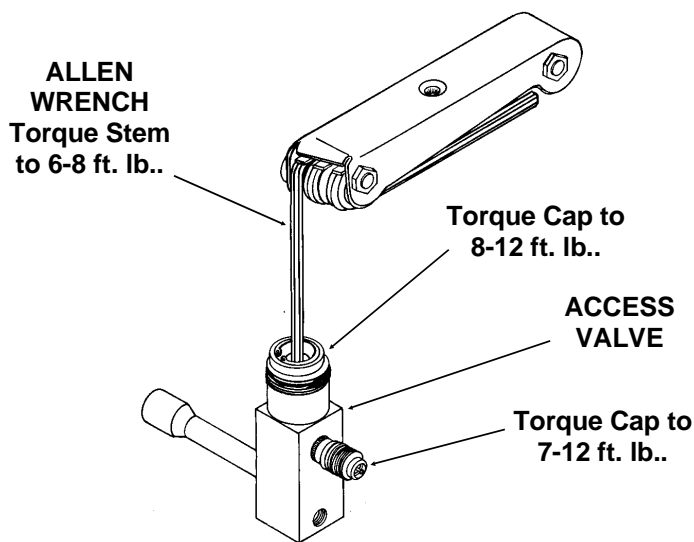

# NME1850R & FME2400R

## CIRCUIT BOARD TESTING

### WARNING

These procedures require the machine to be connected to the power supply. The voltages of the electronic circuit are very low, but **HIGHER VOLTAGES ARE PRESENT IN THE UNIT**. Do not touch anything but the tester while the unit is being checked out. Make all connections to the circuit board with the **ELECTRICAL POWER OFF**.

### INSTRUCTIONS FOR USING TESTER, (Optional, order part no. A33942-001)

*(These instructions assume that the unit **will not run**, and prior investigation of electric power, controls, and mechanical parts indicates that the electronic circuit may be at fault.)*

If the "NO WATER" indicator is lit, but inspection shows that the water level in the reservoir is above the top of the water level sensor, OR the "BIN EMPTY" indicator is off while inspection shows that the ice level sensors are properly aligned, clean and not obstructed, use the tester as follows:

**Bin Control** Note: All testing is done with the electrical power on, the master switch on, and all reset switches "reset".

1. Unplug "photo trans" and "LED" connectors from the circuit board.
2. Plug "photo trans" and "LED" connectors from the tester into the circuit board.

a. Move the "bin full" switch on the tester to Full. The light on the tester should be ON.

If the light on the tester is not on, the circuit board should be replaced.

b. If the light on the tester IS on, move the "bin full" switch to Bin Empty. The light on the tester should go OFF, and the Bin Empty light on the circuit board should go ON.

If the Bin Empty light is ON, wait 10-20 seconds for the machine to start, if the machine starts, replace the ice level sensors.

If the Bin Empty light does not come ON, the circuit board should be replaced.

### Water Level

1. Unplug "water sen" connector from control board.
2. Plug "water sen" connector from Scotsman tester into circuit board.

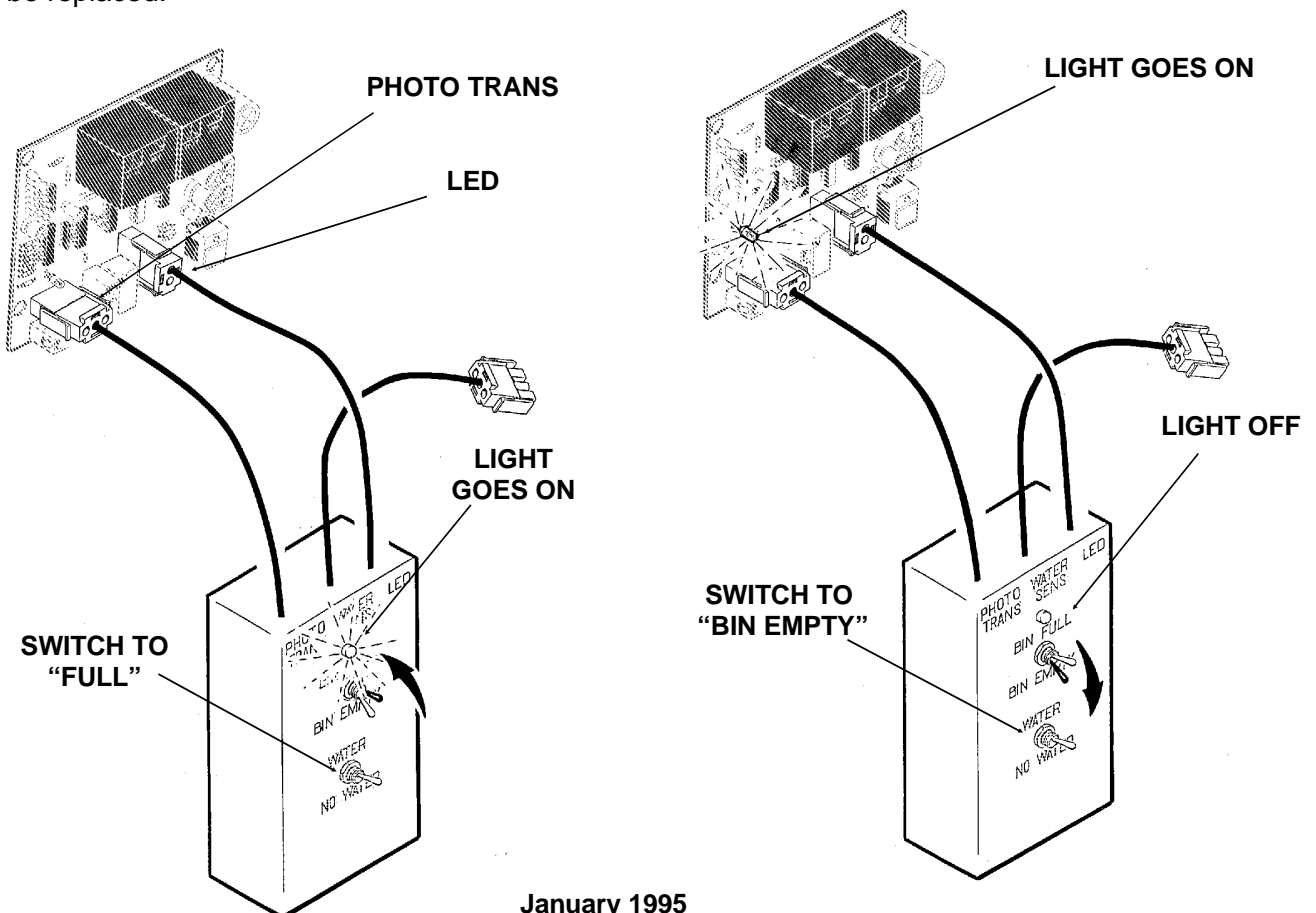

## CIRCUIT BOARD TESTING

a. Move "water" switch on tester to No Water position. The No Water light on the circuit board should go ON. If not, replace the circuit board.

b. Move the "water" switch on the tester to the Water position. The No Water light on the board

should go OFF. If not replace the circuit board. If the light does go off, replace the water level sensor. If the Bin Empty light is ON, wait 10-20 seconds for the machine to start. The machine should start.

